

MINISTART Softstarter With Softstop BA 9018

Translation
of the original instructions



- Softstart with softstop
- For motors up to 5,5 kW
- 2-phase control
- Adjustable ramp time, starting torque and deceleration time
- Width 45 mm

Function Diagram

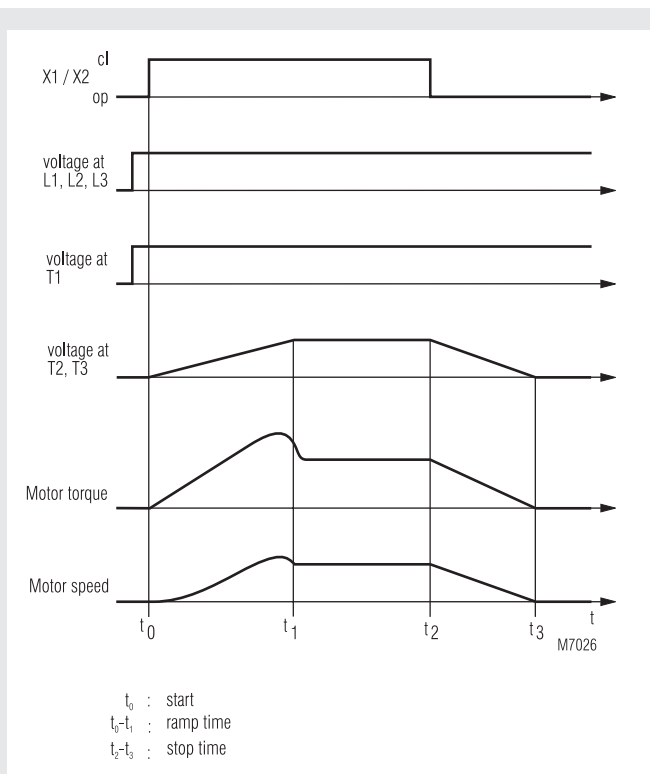

Approvals and Markings



Applications

- Motors with gear, belt or chain drive
- Fans, pumps, conveyor systems, compressors
- Packaging machines, door drives
- Start current limiting on 3 phase motors

Function

Softstarters are electronic devices designed to enable 1-phase or 3-phase induction motors to start smoothly. The BA 9018 slowly ramps up the current on two phases, therefore allowing the motor torque to build up slowly. This reduces the mechanical stress on the machine and prevents damage to conveyed material.

When the motor is up to full speed the semiconductors are bridged to prevent internal power losses and heat build up. In addition BA 9018 allows a softstop function prolonging the stop time of the motor, preventing high counter torques from abruptly stopping the motor.

Indication

LED green	ON	=	Power connected
LED yellow	ON	=	Power semiconductors bridged

Principle of Operation

For direct on line or star delta applications, terminals L1, L2, L3 are connected to the mains contactor, with the motor connected to terminals T1, T2, T3.

Block Diagram

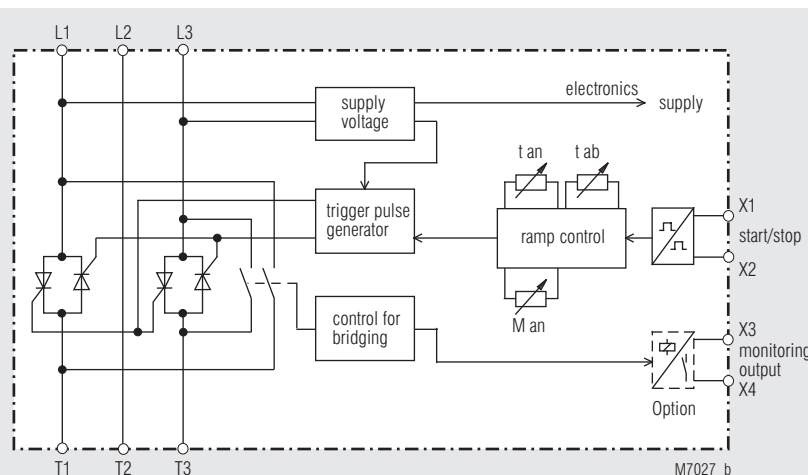

Principle of Operation

When power is connected to terminals L1, L2, L3 and terminals X1 and X2 are bridged the softstart will commence. Potentiometer "t_{an}" (0,5 - 12 s) adjusts the ramp time (time the motor takes to get to full speed) and potentiometer "M_{an}" adjusts the start voltage (0-80% nomV). When the softstart is complete the internal semiconductors are automatically bridged. When terminals X1 and X2 are then broken the softstop function will commence for the deceleration time period set on potentiometer "t_{ab}" (0,5-12 s).

Notes

Motor load must always be connected as continuous operation of the softstart with no load may cause overheating of the motor and softstart. It is recommended that the softstart is protected by superfast semiconductor fuses rated as per the current rating of the softstart or motor. However, standard line and motor protection is acceptable, but for high starting frequencies motor winding temperature monitoring is recommended.

Technical Data

Nominal voltage:	3 AC 400 V ± 15 % (others on request)
* Special voltages up to 480 V can only be made for units > 3 kW. For special voltages > 500 V a separate auxiliary supply is necessary. It has to be connected to terminals X3 and X4. The variant with monitoring contacts (/100) is not possible in this case. Auxiliary supply is either 230 V AC or 24 V DC.	
Nominal frequency:	50/60 Hz
Rated current:	3,5; 6,5; 12 A
Nominal motor power at P_N at 400 V:	1,5; 3; 5,5 kW
Min. motor power:	Approx. 40% for rated motor power
Start torque:	0 ... 80 %
Ramp time:	0,5 ... 12 s
Deceleration time:	0,5 ... 12 s
Recovery time:	200 ms
Switching frequency at 3 x I_N and t_{an} = 5 s:	200/h; 120/h; 70/h
Semiconductor fuse I²t-value:	72 A ² s; 265 A ² s; 610 A ² s

General Data

Temperature range:	0 ... + 45°C	
Storage temperature:	- 25 ... + 75°C	
Degree of protection:		
Housing:	IP 40	
Terminals:	IP 20	
Climate resistance:	25 / 075 / 04	IEC/EN 60068-1
Wire connection:	Up to 2,5 mm ² stranded ferruled	
Mounting:	DIN-rail mounting	
Weight:	400 g	
Special voltages:	230; 230; 230 V - 480; 480 V	

Dimensions

Width x height x depth: 45 x 74 x 121 mm

Standard Type

BA 9018	3 AC 400 V	50/60 Hz	1,5 kW	
Article number:	0047690			stock item
• Nominal voltage:	3 AC 400 V			
• Nominal motor power:	1,5 kW			
• Width:	45 mm			

Variants

BA 9018/010:	Start via control input X1, X2 DC 10 ... 42 V
BA 9018/100:	X3, X4 closed when motor on operation
BA 9018/101:	X3, X4 closed when semiconductors bridged

Ordering example for variants

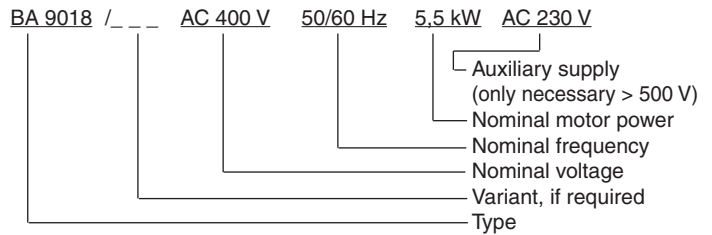

Control Input

As described in Principles of Operation BA 9018 are normally controlled by a voltfree contact on terminals X1-X2.

BA 9018/010:

If external DC voltage control is desired the BA 9018 can be set at the factory to accept a DC control voltage of 10 ... 42 V DC at terminals X1+,X2-.

Installation

The softstarter must be mounted on a vertical mounting area with the connections in a vertical plane, i. e. top to bottom. Ensure that no external heat source is placed below the unit and a 40 mm air gap is maintained above and below. Other devices may be directly mounted either side of the unit.

Set-up Procedure

Set potentiometer "M_{an}" to minimum (fully anti-clockwise).
Set potentiometer "t_{an}" to maximum (fully clockwise).
Set potentiometer "t_{ab}" to mid position.
Start the motor and turn potentiometer "M_{an}" up until the motor starts to turn without excessive humming.
Stop the motor and restart.
Adjust potentiometer "t_{an}" to give the desired ramp time.
Stop and restart the motor.
Adjust potentiometer "t_{ab}" to give the desired deceleration time.
Stop and restart the motor, readjusting the potentiometers until the desired starting/stopping characteristics are achieved.

- **Attention:** If the ramp-up time is adjusted to short, the internal bridging contact closes before the motor is on full speed. This may damage the bridging contactor or bridging relay.



Safety Notes

- Never clear a fault when the device is switched on
- **Attention:** This device can be started by potential-free contact, while connected directly to the mains without contactor (see application example). Please note, that even if the motor is at rest, it is not physically separated from the mains. Because of this the motor **must** be disconnected from the mains via the corresponding manual motor starter.
- The user must ensure that the device and the necessary components are mounted and connected according to the locally applicable regulations and technical standards.
- Adjustments may only be carried out by qualified specialist staff and the applicable safety rules must be observed.



Connection Example

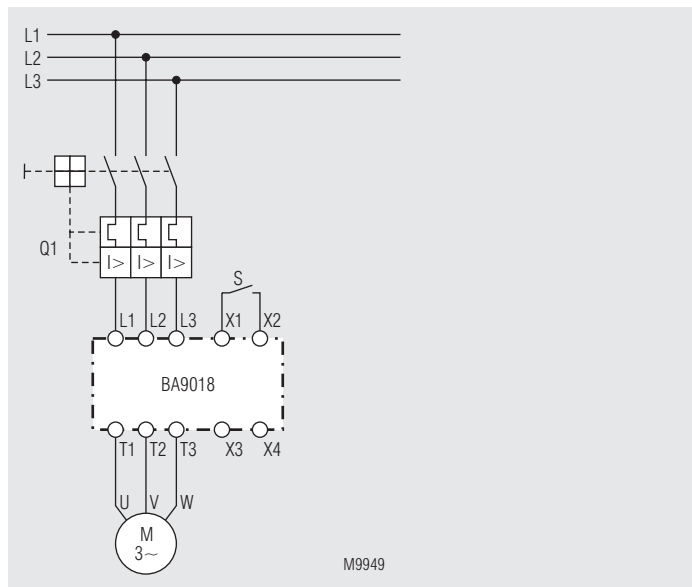

Softstart with softstop

