

Absolute encoders - SSI

Solid shaft with clamping or synchro flange

Optical multiturn encoders up to 14 bit ST / 16 bit MT

GM400, GM401



GM400 with clamping flange

Technical data - electrical ratings

Voltage supply	10...30 VDC 5 VDC \pm 10 %
Reverse polarity protection	Yes (10...30 VDC) / No (5 VDC)
Consumption w/o load	\leq 50 mA (24 VDC) \leq 80 mA (5 VDC)
Initializing time typ.	20 ms after power on
Interfaces	SSI, Incremental A 90° B (optional)
Function	Multiturn
Steps per turn	\leq 16384 / 14 bit
Number of turns	\leq 65536 / 16 bit
Incremental output	2048 pulses A90°B + inverted
Absolute accuracy	\pm 0.025 °
Sensing method	Optical
Code	Gray or binary
Code sequence	CW/CCW coded by connection
Inputs	SSI clock Control signals UP/DOWN and zero
Output stages	SSI data: linedriver RS485 Diagnostic outputs push-pull
Interference immunity	DIN EN 61000-6-2
Emitted interference	DIN EN 61000-6-4
Diagnostic functions	Self-diagnosis Multiturn sensing
Approval	UL approval / E63076

Features

- Encoder multiturn / SSI
- Optical sensing method
- Resolution: max. singleturn 14 bit, multiturn 16 bit
- Clamping or synchro flange
- Electronic setting of zero point
- Counting direction input
- Available with additional incremental output
- Maximum resistant against magnetic fields

Optional

- Stainless steel design
- Corrosion protection for offshore applications

Technical data - mechanical design

Size (flange)	\varnothing 58 mm
Protection DIN EN 60529	IP 54 (without shaft seal), IP 65 (with shaft seal)
Operating speed	\leq 10000 rpm (mechanical) \leq 6000 rpm (electric)
Starting acceleration	\leq 1000 U/s ²
Starting torque	\leq 0.015 Nm (IP 54) \leq 0.03 Nm (IP 65)
Rotor moment of inertia	20 gcm ²
Admitted shaft load	\leq 20 N axial \leq 40 N radial
Materials	Housing: steel Flange: aluminium
Operating temperature	-25...+85 °C -40...+85 °C (optional)
Relative humidity	95 % non-condensing
Resistance	DIN EN 60068-2-6 Vibration 10 g, 16-2000 Hz DIN EN 60068-2-27 Shock 200 g, 6 ms
Weight approx.	400 g
Connection	Connector M23, 12-pin Cable 1 m
GM400	
Shaft type	\varnothing 10 mm solid shaft
Flange	Clamping flange
GM401	
Shaft type	\varnothing 6 mm solid shaft
Flange	Synchro flange

Absolute encoders - SSI

Solid shaft with clamping or synchro flange

Optical multiturn encoders up to 14 bit ST / 16 bit MT

GM400, GM401

Part number

Clamping flange

GM400.

Pulses / Incremental output

- 02 No incremental output
- 04 2048 pulses / push-pull
- 06 2048 pulses / RS422
- 07 2048 periods / SinCos
- 24 1024 pulses / push-pull
- 26 1024 pulses / RS422
- 27 1024 periods / SinCos
- 34 512 pulses / push-pull
- 36 512 pulses / RS422
- 37 512 periods / SinCos

Connection

- A0 Connector M23, 12-pin, axial
- A1 Connector M23, 12-pin, radial
- A2 Connector M23, 12-pin, axial, for incremental output 04/06/07/24/26/27/34/36/37
- A3 Connector M23, 12-pin, radial, for incremental output 04/06/07/24/26/27/34/36/37
- 11 Cable 1 m, axial
- 21 Cable 1 m, radial
- 31 Cable 1 m, axial, for incremental output 04/06/07/24/26/27/34/36/37
- 41 Cable 1 m, radial, for incremental output 04/06/07/24/26/27/34/36/37

Voltage supply / signals

- 10 10...30 VDC / gray code 25 bit (ST 13 + MT 12)
- 11 5 VDC / gray code 25 bit (ST 13 + MT 12)
- 12 10...30 VDC / binary code 25 bit (ST 13 + MT 12)
- 13 5 VDC / binary code 25 bit (ST 13 + MT 12)
- 20 10...30 VDC / gray code 24 bit (ST 12 + MT 12)
- 30 10...30 VDC / gray code 25 bit (ST 13 + MT 12) + parity
- 40 10...30 VDC / gray code 24 bit (ST 12 + MT 12) + DV
- 90 10...30 VDC / gray code 26 bit (ST 14 + MT 12)
- 92 10...30 VDC / binary code 26 bit (ST 14 + MT 12)
- A0 10...30 VDC / gray code 29 bit (ST 13 + MT 16)

Flange / Solid shaft

- 0 Clamping flange / ø10 mm, IP 54
- A Clamping flange / ø10 mm, IP 65

Subject to modification in technic and design. Errors and omissions excepted.

Absolute encoders - SSI

Solid shaft with clamping or synchro flange

Optical multiturn encoders up to 14 bit ST / 16 bit MT

GM400, GM401

Part number

Synchro flange

GM401.

Pulses / Incremental output

- 02 No incremental output
- 04 2048 pulses / push-pull
- 06 2048 pulses / RS422
- 07 2048 periods / SinCos
- 24 1024 pulses / push-pull
- 26 1024 pulses / RS422
- 27 1024 periods / SinCos
- 34 512 pulses / push-pull
- 36 512 pulses / RS422
- 37 512 periods / SinCos

Connection

- A0 Connector M23, 12-pin, axial
- A1 Connector M23, 12-pin, radial
- A2 Connector M23, 12-pin, axial, for incremental output 04/06/07/24/26/27/34/36/37
- A3 Connector M23, 12-pin, radial, for incremental output 04/06/07/24/26/27/34/36/37
- 11 Cable 1 m, axial
- 21 Cable 1 m, radial
- 31 Cable 1 m, axial, for incremental output 04/06/07/24/26/27/34/36/37
- 41 Cable 1 m, radial, for incremental output 04/06/07/24/26/27/34/36/37

Voltage supply / signals

- 10 10...30 VDC / gray code 25 bit (ST 13 + MT 12)
- 11 5 VDC / gray code 25 bit (ST 13 + MT 12)
- 12 10...30 VDC / binary code 25 bit (ST 13 + MT 12)
- 13 5 VDC / binary code 25 bit (ST 13 + MT 12)
- 20 10...30 VDC / gray code 24 bit (ST 12 + MT 12)
- 30 10...30 VDC / gray code 25 bit (ST 13 + MT 12) + parity
- 40 10...30 VDC / gray code 24 bit (ST 12 + MT 12) + DV
- 90 10...30 VDC / gray code 26 bit (ST 14 + MT 12)
- 92 10...30 VDC / binary code 26 bit (ST 14 + MT 12)
- A0 10...30 VDC / gray code 29 bit (ST 13 + MT 16)

Flange / Solid shaft

- 1 Synchro flange / ø6 mm, IP 54
- B Synchro flange / ø6 mm, IP 65

Absolute encoders - SSI

Solid shaft with clamping or synchro flange

Optical multiturn encoders up to 14 bit ST / 16 bit MT

GM400, GM401

Accessories

Connectors and cables

Z 130.001	Female connector M23, 12-pin, without cable
Z 130.003	Female connector M23, 12-pin, 2 m cable
Z 182.001	Female connector M23, 12-pin, without cable (incr.)
Z 182.003	Female connector M23, 12-pin, 2 m (incr.)

Mounting accessories for GM400

Z 119.006	Eccentric fixing, single
Z 119.013	Adaptor plate for clamping flange for modification into synchro flange
Z 119.017	Mounting adaptor for clamping flange (M3)

Mounting accessories for GM401

Z 119.006	Eccentric fixing, single
Z 119.015	Mounting adaptor for synchro flange
Z 119.035	Bearing flange for encoders with synchro flange

Data transfer

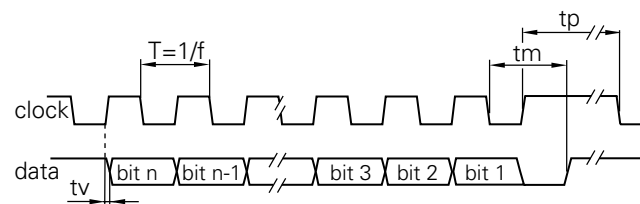

Clock frequency f	62.5...1500 kHz
Duty cycle of T	40...60 %
Delay time tv	150 ns
Monoflop time tm	26 μs + T/2
Clock interval tp	30 μs

Trigger level

SSI	Circuit
SSI-Clock	Optocoupler
SSI-Data	Linedriver RS485

Control inputs

Control inputs	Input circuit
Input level High	>0.7 UB
Input level Low	<0.3 UB
Input resistance	10 kΩ

Diagnostic outputs or Incremental outputs

Diagnostic outputs or Incremental outputs	Output circuit Push-pull circuit-proof
Output level High	>UB -3.5 V (I = -20 mA)
Output level Low	<0.5 V (I = 20 mA)
Load High / Low	<20 mA

Incremental outputs

Incremental outputs	Linedriver RS422
Output level High	>2.5 V (I = -20 mA)
Output level Low	<0.5 V (I = 20 mA)
Load High / Low	<20 mA

Outputs

Outputs	SinCos
Output level	1 Vpp ±10 %
Load	<10 mA

Absolute encoders - SSI

Solid shaft with clamping or synchro flange

Optical multiturn encoders up to 14 bit ST / 16 bit MT

GM400, GM401

Terminal significance	
UB	Encoder voltage supply.
GND	Encoder ground connection relating to UB.
Data+	Positive, serial data output of differential linedriver.
Data-	Negative, serial data output of differential linedriver.
Clock+	Positive SS clock input. Clock+ together with clock- forms a current loop. A current of approx. 7 mA towards clock+ input means logic 1 in positive logic.
Clock-	Negative SSI clock input. Clock- together with clock+ forms a current loop. A current of approx. 7 mA towards clock- input means logic 0 in positive logic.
Zero setting	Input for setting a zero point anywhere within the programmed encoder resolution. The zero setting operation is triggered by a High impulse and has to be in line with the selected direction of rotation (UP/DOWN). Connect to GND after setting operation for maximum interference immunity. Impulse duration ≥ 100 ms.
$\overline{\text{DATAVALID}}$	Diagnostic output. An error warning is given at level Low. Important: Interferences must be drained by the downstream electronics.
$\overline{\text{DATAVALID MT}}$	Diagnostic output for monitoring the multiturn sensor voltage supply. Upon dropping below a defined voltage level the $\overline{\text{DV MT}}$ output is switched to Low.
$\overline{\text{UP/DOWN}}$	$\overline{\text{UP/DOWN}}$ counting direction input. This input is standard on High. $\overline{\text{UP/DOWN}}$ means ascending output data with clockwise shaft rotation when looking at flange. $\overline{\text{UP/DOWN-Low}}$ means ascending values with counterclockwise shaft rotation when looking at flange.
Incremental Outputs	Incremental tracks A 90° B and inverted.

Terminal assignment			
GM400, GM401			
Connector	Core colour	Assignment	
Pin 1	brown	UB	
Pin 2	black	GND	
Pin 3	blue	Clock+	
Pin 4	beige	Data+	
Pin 5	green	Zero setting	
Pin 6	yellow	Data-	
Pin 7	violet	Clock-	
Pin 8	brown/yellow	$\overline{\text{DATAVALID}}$	
Pin 9	pink	$\overline{\text{UP/DOWN}}$	
Pin 10	black/yellow	$\overline{\text{DATAVALID MT}}$	
Pin 11-12	–	–	
GM400, GM401 with incremental tracks SinCos			
Connector	Core colour	Assignment Incremental	SinCos
Pin 1	brown	UB	UB
Pin 2	white	GND	GND
Pin 3	blue	Clock+	Clock+
Pin 4	green	Data+	Data+
Pin 5	grey	Zero setting	Zero setting
Pin 6	yellow	Data-	Data-
Pin 7	red	Clock-	Clock-
Pin 8	red/blue	Track B inv.	$\overline{\text{Cosine}}$
Pin 9	pink	$\overline{\text{UP/DOWN}}$	$\overline{\text{UP/DOWN}}$
Pin 10	violet	Track A inv.	$\overline{\text{Sine}}$
Pin 11	black	Track A	Sine
Pin 12	grey/pink	Track B	Cosine

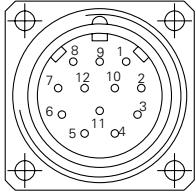

Please use cores twisted in pairs (for example clock+ / clock-) for extension cables of more than 10 m length.

Absolute encoders - SSI

Solid shaft with clamping or synchro flange

Optical multiturn encoders up to 14 bit ST / 16 bit MT

GM400, GM401

Dimensions

GM400 - clamping flange

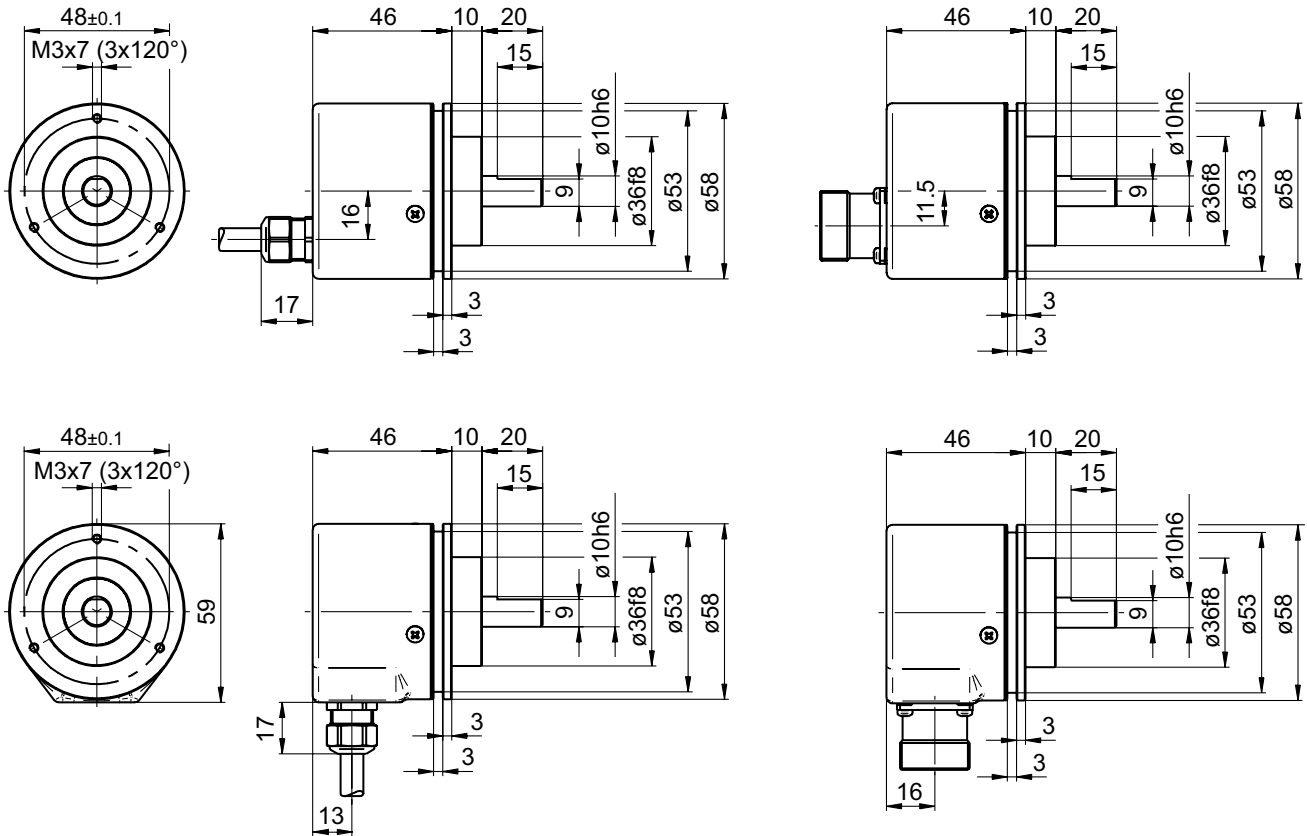

GM401 - synchro flange

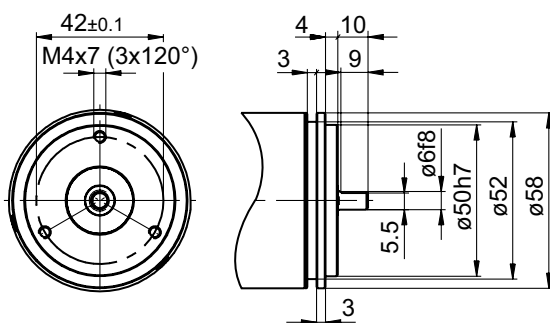

GM400, GM401 - connector dimensions

