



# SERIE HM10

MULTITURN ABSOLUTE ENCODER

PARALLEL

- Parallel
- Singleturn resolution up to 13 bits
- Multiturn resolution up to 24 bits
- External diameter 58 mm
- Shaft  $\varnothing$  10 or 12 mm
- Protection class IP65 according to DIN EN 40050
- Connection by cable (other cable length available) or industrial connector



Optical Encoder   Absolute Encoder   Vibration and shock resistant   IP65   Temperature range   Express Delivery

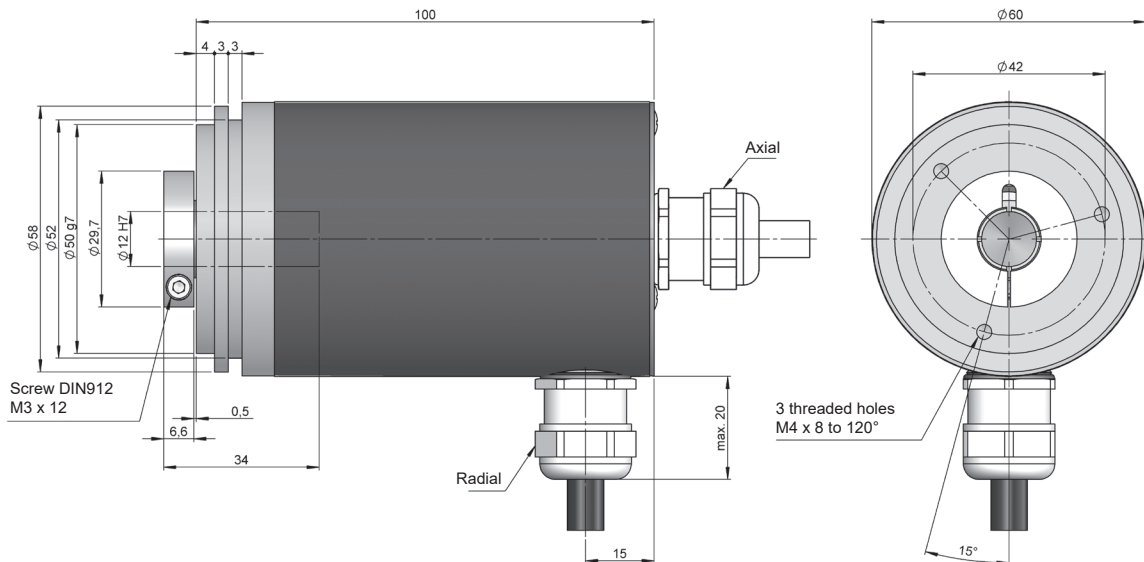

Drawing shaft type 1, connection type 11/12, without flange

## REFERENCE

Reference example: HM10-32110212S-1024/2048

Serie	Blind-Hollow shaft	Anti-rotation system	Connection	Interface	Code	IP	Power Supply / Electronic output	Parameters config.	Singleturn resolution	Multiturn resolution	Special customer
HM10 -	<input type="checkbox"/>	<input type="checkbox"/>	<input type="checkbox"/>	<input type="checkbox"/>	<input type="checkbox"/>	<input type="checkbox"/>	<input type="checkbox"/>	<input type="checkbox"/>	<input type="checkbox"/>	<input type="checkbox"/>	<input type="checkbox"/>
	3. $\varnothing$ 12 mm 4. $\varnothing$ 10 mm	1. None	11. Axial cable 12. Radial cable 31. Axial M23 12p 32. Radial M23 12p 41. Axial M23 16p 42. Radial M23 16p 51. Axial M27 21p 52. Radial M27 21p 61. Axial M27 26p 62. Radial M27 26p	0. Parallel	1. Binary CW 2. Binary CCW 3. Gray CW 4. Gray CCW 5. Gray excess CW 6. Gray excess CCW	1. IP65	2. 10...30 VDC / NPN 3. 10...30 VDC / Push-Pull 4. 10...30 VDC / NPN OC	Blank. None S. Direction			

Order your reference  
Step file 3D

info@encoderhohner.com  
service available in 24 h



# SERIE HM10

## MULTITURN ABSOLUTE ENCODER

PARALLEL

### MECHANICAL SPECIFICATIONS

Materials	Housing: Steel Flange: Aluminium Shaft: Stainless Steel
Bearings	Ballraces
Bearings lifetime	1x10 <sup>10</sup> rev.
Housing fixing	Flexible flange
Shaft fixing	Clamp
Permitted misalignment	± 0.5 mm axial, ±0.3 mm radial
Blind hollow shaft diameter	10 or 12 mm
Maximum number of revolutions permitted mechanically	6000 rpm
Protection against dust and splashes according to DIN EN 40050	IP65
Rotor inertia moment	30 gcm <sup>2</sup>
Starting torque at 20°C (68°F)	≤ 0,02 Nm
Maximum load permitted on axial shaft	40 N
Maximum load permitted on radial shaft	60 N
Weight aprox.	0,5 Kg
Operating temperature range	-10°C to +70°C
Vibration	100 m/s <sup>2</sup> (10Hz...2000Hz)
Shock	1000 m/s <sup>2</sup> (6ms)
Axial or radial connection	2 meters cable or industrial connector (other cable lengths available on order) <b>Female connector not included</b>

### OUTPUT SIGNALS

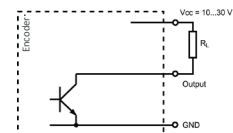
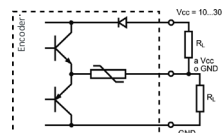
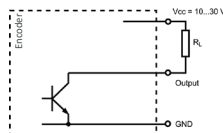

OUTPUT CIRCUIT	NPN	Push-Pull	NPN Open Collector
Reference code	2	3	4
Power supply	10...30 VDC	10...30 VDC	10...30 VDC
Consumption max.	150 mA	150 mA	150 mA
Max. load capability / channel	40 mA	±30 mA	40 mA
"Low" signal level	VOL < 2.5 VDC	VOL < 2.5 VDC	VOL < 2.5 VDC
"High" signal level	VOH > VCC - 3V	VOH > VCC - 3V	VOH > VCC - 3V
Frequency	200 kHz	200 kHz	200 kHz

# SERIE HM10

## MULTITURN ABSOLUTE ENCODER

## PARALLEL

### ELECTRICAL SPECIFICATIONS

Interface	Parallel
Inputs	Opto-coupled
Code	Binary Gray
Singleturn resolution	up to 8192 points per turn (13 bits) (*)
Multiturn resolution	up to 4096 turns (12 bits)
Linearity	±1/2 LSB
Parameters config.	Direction

(\*) 8192 points per turn (13 bits) only available for multiturn resolution up to 2048 points per turn (11 bits).

### CONNECTION

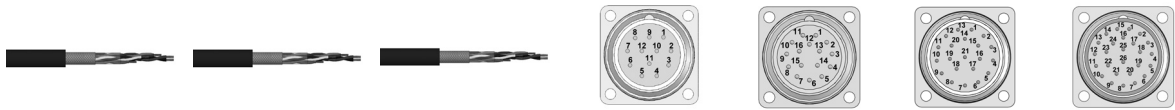

	Cable 15x0,14 mm <sup>2</sup> 95.0008031	Cable 25x0,14 mm <sup>2</sup> 95.0008030	Cable 36x0,14 mm <sup>2</sup> 95.0008032	Connector M23 12p CW	Connector M23 16p CW	Connector M27 21p CW	Connector M27 26p CW
GND	Black	Black	Black	1	1	1	1
VCC	Red	Red	Red	2	2	2	2
Bit 0	Brown	Brown	Brown	3	3	3	3
Bit 1	White	White	White	4	4	4	4
Bit 2	Yellow	Yellow	Yellow	5	5	5	5
Bit 3	Green	Green	Green	6	6	6	6
Bit 4	Orange	Pink	Pink	7	7	7	7
Bit 5	Violet	Orange	Orange	8	8	8	8
Bit 6	Grey	Grey	Grey	9	9	9	9
Bit 7	Blue	Blue	Blue	10	10	10	10
Bit 8	White - Black	Yellow - Black	Yellow - Black	11	11	11	11
Bit 9	White - Red	Yellow - Red	Yellow - Red	12	12	12	12
Bit 10	White - Brown	Yellow - Brown	Yellow - Brown		13	13	13
Bit 11	White - Yellow	Yellow - Green	Yellow - Green		14	14	14
Bit 12	White - Blue	Yellow - Grey	Yellow - Pink		15	15	15
Bit 13		Yellow - Blue	Yellow - Grey		16	16	16
Bit 14		White - Black	Yellow - Blue			17	17
Bit 15		White - Red	White - Black			18	18
Bit 16		White - Brown	White - Red			18	19
Bit 17		White - Green	White - Brown			19	20
Bit 18		White - Pink	White - Green			20	21
Bit 19		White - Orange	White - Pink			21	22
Bit 20		White - Grey	White - Orange				23
Bit 21		White - Blue	White - Grey				24
Bit 22			White - Blue				25
Bit 23			Green - Black				26
DIR	White - Yellow	Yellow - Pink	Grey - Brown	11	15	20	25
RES	White - Blue	White - Blue	Grey - Blue	12	16	21	26

# SERIE HM10

## MULTITURN ABSOLUTE ENCODER

PARALLEL

### CONNECTION DIMENSIONS

Female connector not included

#### Connection 31

Axial  
M23 12p  
male panel  
clockwise

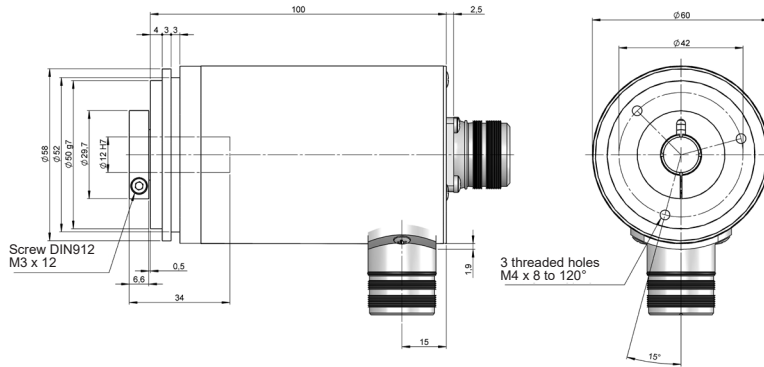

Female connector  
95.0007131

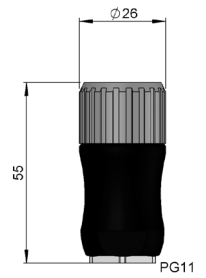

#### Connection 32

Radial  
M23 12p  
male panel  
clockwise

#### Connection 41

Axial  
M23 16p  
male panel  
clockwise

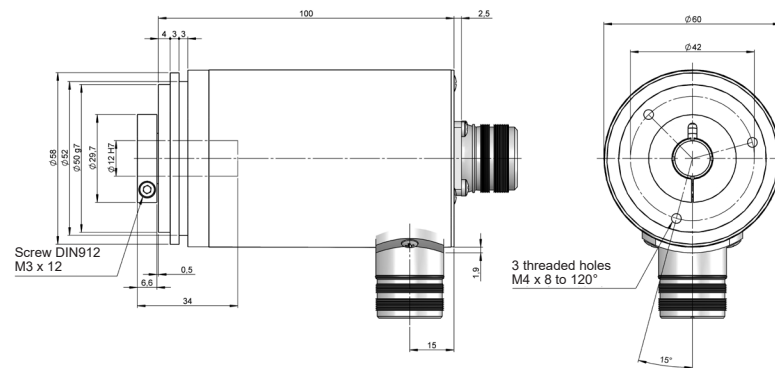

Female connector  
95.0007006

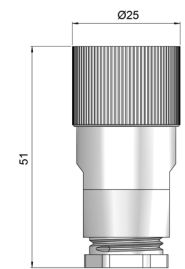

#### Connection 42

Radial  
M23 16p  
male panel  
clockwise

#### Connection 51

Axial  
M27 24p  
male panel  
clockwise

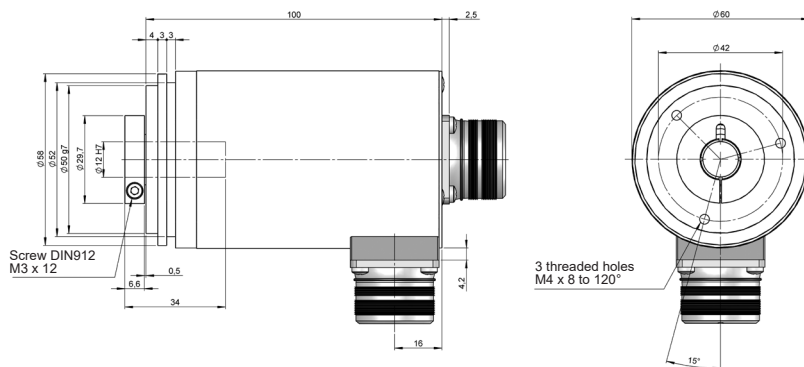

Female connector  
95.0007062

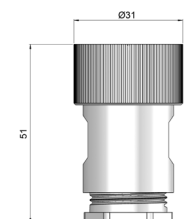

#### Connection 52

Radial  
M27 24p  
male panel  
clockwise

# SERIE HM10

## MULTITURN ABSOLUTE ENCODER

## PARALLEL

### Connection 61

Axial  
M27 26p  
male panel  
clockwise

### Connection 62

Radial  
M27 26p  
male panel  
clockwise

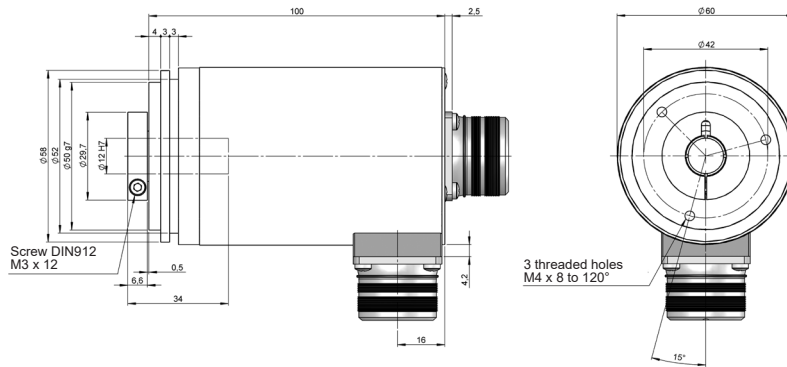

**Female connector**  
95.0007063

