

INTERBUS-S

Absolute Encoder CE-65-M

- _ Safety Information**
- _ Assembly**
- _ Commissioning**
- _ Cause of faults and remedies***

User Manual

TR-Electronic GmbH

D-78647 Trossingen

Eglishalde 6

Tel.: (0049) 07425/228-0

Fax: (0049) 07425/228-33

email: info@tr-electronic.de

www.tr-electronic.com

Copyright protection

This Manual, including the illustrations contained therein, is subject to copyright protection. Use of this Manual by third parties in contravention of copyright regulations is not permitted. Reproduction, translation as well as electronic and photographic archiving and modification require the written content of the manufacturer. Violations shall be subject to claims for damages.

Subject to modifications

The right to make any changes in the interest of technical progress is reserved.

Document information

Release date / Rev. date:	04/04/2016
Document / Rev. no.:	TR - ECE - BA - GB - 0007 - 03
File name:	TR-ECE-BA-GB-0007-03.docx
Author:	MÜJ

Font styles

Italic or **bold** font styles are used for the title of a document or are used for highlighting.

`Courier` font displays text, which is visible on the display or screen and software menu selections.

" < > " indicates keys on your computer keyboard (such as <RETURN>).

Contents

Contents	3
Revision index	4
1 Safety	5
1.1 General Potential for Danger	5
1.2 Safety Information.....	5
1.2.1 Installation Information.....	6
1.2.1.1 Screening.....	7
1.2.1.2 General Measures for Interference Suppression	7
1.3 Appropriate Use.....	8
1.4 Authorized Operators.....	9
1.5 Safety Measures at the Place of Assembly	9
1.6 Protective Devices	10
2 Transportation/Commissioning	11
2.1 Transportation/Storage.....	11
2.2 Technical Data.....	12
2.2.1 Electrical Characteristic Data.....	12
2.2.2 Mechanical Characteristic Data	13
2.2.3 Pin Assignments	14
2.3 Assembly	16
2.4 Commissioning (Rotary Encoder).....	17
2.4.1 Encoder Interface (INTERBUS-S)	17
2.4.1.1 Mapping of Encoder Data in the Master (Controller)	18
3 Parameter Programming (Operation).....	20
3.1 Callable Services	20
3.1.1 Direction of Counting/Code – Service 01 Hex	21
3.1.2 Measuring Length in Steps – Service 02 Hex.....	21
3.1.3 Measuring Length in Revolutions Numerator – Service 03 Hex.....	22
3.1.4 Preset Adjustment – Service 06 Hex	22
3.1.5 Data Check – Service 08 Hex.....	23
3.1.6 Measuring Length in Revolutions Denominator – Service 09 Hex	23
3.1.7 SSI-OUT Data Interface.....	24
3.1.7.1 SSI Characteristic Values – Service 0D Hex	24
3.2 Brief Description of Executable Services.....	25
3.2.1 Direction of Counting/Code – Service 01 Hex	25
3.2.2 Measuring Length in Steps – Service 02 Hex.....	25
3.2.3 Measuring Length in Revolutions (Numerator) – Service 03 Hex, Measuring Length in Revolutions (Denominator) – Service 09 Hex.....	25
3.2.4 Preset Adjustment – Service 06 Hex	26
3.2.5 Data Check – Service 08 Hex.....	26
3.2.6 SSI-OUT Data Interface.....	27
3.2.6.1 SSI Characteristic Values – Service 0D Hex	27
3.3 Example of Programming the Measuring Length in Steps	28
4 Disturbances.....	29
4.1 Causes of Faults and Remedies.....	29

Revision index

Revision	Date	Index
First release	07/31/96	00
Modifications of the chapter "Pin Assignments": Description of the status-LED's	02/24/97	01
Completion of the service 0D hex (SSI characteristic values): An additional SSI-output format is guaranteed compatibility to the TR-component AK-40	10/10/97	02
General modifications	04/04/16	03

1 Safety

1.1 General Potential for Danger

The CE-65-M rotary encoder cannot function as a stand-alone unit, i.e. it is a component part that is intended to be installed in a complete system consisting of several such components working together. This means that the rotary encoder does not have a direct protection device of its own.

Using the transfer log, the system can, however, output an error bit that shows an error in internal data transfer or that a parameter was assigned an illegal value. To reset the error bit, the error must be acknowledged. It is therefore crucial to integrate the error bit into **your own safety concept**, via the evaluation software (e.g. of a PLC).

(For more information, refer to section **Fehler! Verweisquelle konnte nicht gefunden werden.**, Protective Devices on page 10).

The encoder provides no diagnostics for errors that may occur, such as speed too high, track errors, transfer errors, etc. This means that you must check the received data yourself for validity.

All the persons who are involved in the assembly, commissioning and operation of the device

- must be appropriately qualified
- must follow exactly the instructions in this manual.

This is for your own safety and the safety of your equipment!

1.2 Safety Information

This operating manual contains information that you must comply with to ensure your personal safety and to avoid damage to property. The information is emphasized by warning triangles, which have different appearances to match the level of danger:



Warning

Means that if the appropriate safety measures are ignored, death, severe injury or considerable damage to property can occur.



Caution

Means that if the appropriate safety measures are ignored, slight injury or damage to property can occur.



Note

Emphasizes important information about the product, its properties or helpful hints for using it.

1.2.1 Installation Information

Due to the fact that the rotary encoder is normally used as a component part of a larger system, this information is intended to provide a guideline for safe installation of the rotary encoder in its environment.



Warning

- Observe the safety and accident prevention regulations that apply to the specific application.
- In the case of equipment with a fixed connection (stationary installations/systems) without allpole mains switches and/or fuses, you must install a mains switch or a fuse in the system and connect the equipment to a protective earth.
- Before commissioning devices that are run with mains voltage, check whether the set rated voltage range matches the local mains voltage.
- With a 24-V supply, ensure safe electrical isolation of the extra-low voltage. Use only mains units that comply with IEC 364-4-41 or HD 384.04.41 (VDE 0100 Part 410) standards.
- Fluctuations in or deviations from the rated mains voltage may not exceed the tolerances stated in the technical data. If they do, functional failures of the electrical components and hazardous conditions cannot be ruled out.
- You must take precautions to ensure that, following voltage dips and failures, it is possible to restart an interrupted program in an orderly manner. In this context, no dangerous operating status conditions may occur even for a brief period of time. If necessary, you must force an **EMERGENCY STOP**.
- EMERGENCY STOP devices that comply with EN 60204/IEC 204 (VDE 0113) must remain effective in all the operating modes of the automation equipment. Unlocking the EMERGENCY STOP devices must not result in an uncontrolled or undefined restart.
- Install the connecting and signal lines such that inductive and capacitive interference does not adversely affect the automation functions.
- Install automation technology equipment and its operator input elements such that they are sufficiently protected against being operated by mistake.
- Take appropriate hardware and software measures in the I/O link to prevent possible cable or wire breakages on the signal side leading to undefined status conditions in the automation equipment.

1.2.1.1 Screening

The use of electronic sensor active systems in modern machines makes it crucial to enforce a consistent and correctly executed interference suppression and wiring concept.

These conditions are the only guarantee that systems containing electronic measuring systems will function properly.

Recommended Screened Cable Wiring

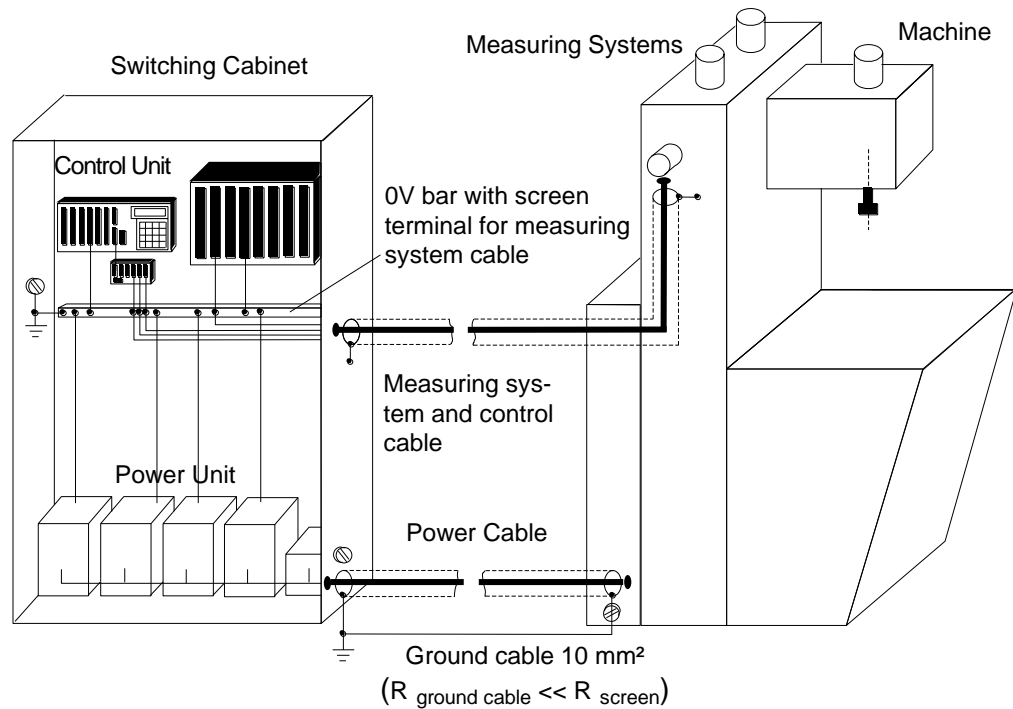

1.2.1.2 General Measures for Interference Suppression

- Route (screened) lines connecting to the encoder either a long way from or completely physically separated from energy lines that carry disturbances.
- Use only completely screened lines for data transfer and ensure they are well earthed. In the case of differential data transfer, (RS422, RS485 etc.), you must additionally use twisted-pair lines.
- Use cables with a minimum cross-section of 0.22 mm² for data transfer.
- Use a ground cable with a minimum cross-section of 10 mm² to avoid equipotential bonding via the screen. In this context, you should ensure that the ground cable's resistance must be much lower than the screen's resistance.
- Wire the screen continuously keeping a large area in contact with special screen connecting terminals.
- Avoid crossing cable. If this is not possible the cables should only cross at right-angles.

1.3 Appropriate Use

The rotary encoder is used to acquire angular motions as well as to condition measuring data for a controller on the output side which has a DIN 19258-standard INTERBUS-S field bus interface. In addition, the rotary encoder has an SSI data interface to allow synchronous-serial transfer of angular data.

The CE-65-M absolute encoder with INTERBUS-S interface is designed as a remote bus module with 32 I/O data. As a result, the device is integrated in the bus ring in the same way as with a PHOENIX-CONTACT bus terminal and the system also processes it as such.



Warning

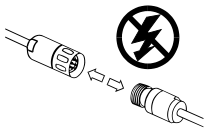

Deenergize the system before carrying out wiring or opening and closing electrical connections!

Short-circuits, voltage peaks etc. can lead to malfunctions and uncontrolled conditions in the system or to serious personal injury or damage to property.

Before switching on the system, check all the electrical connections!

Connections that are made incorrectly can lead to system malfunctions; wrong connections may result in serious personal injury or damage to property.

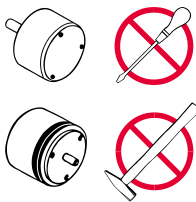

For safety reasons, mechanical or electrical changes to the measuring systems are prohibited!



Caution

***Avoid excessive bearing loadings due to radial and axial deviations between the encoder and the drive shaft!**

At assembly, you must use couplings that can take up these forces.

***Protect the encoder from excessive vibrations, shocks and jolts, e.g. on presses!**

Use "shock modules" to cushion vibrations.



Note

Always keep to the commissioning, operating and programming instructions specified in this manual.

* Observe the mechanical characteristics on page 13.

1.4 Authorized Operators

This/a device may only be commissioned by qualified personnel. In the context of the safety-specific information in this document, qualified personnel are considered to be persons who are authorized to commission, ground and mark circuits, equipment and systems in accordance with recognized safety standards.

1.5 Safety Measures at the Place of Assembly



Warning

Do not carry out welding if the encoder has already been wired-up or is switched-on!

Potential fluctuations can destroy the encoder or adversely affect its function.

Keep to the supply voltage range: 11-27 V DC ($\pm 5\%$ residual ripple)



Note

Ensure that the area around the place of assembly is protected from aggressive media (acid, etc.).

1.6 Protective Devices



Note

For the description below, you should first have read and understood the entire operating manual.

Error Polling and Error Acknowledgement

If an error occurs while one of the services is being carried out, the system sets error bit 2^{29} in the encoder's service feedback message. The Data check service acknowledges and resets a set error bit.

IN data relative to master:

Relative word address "1"

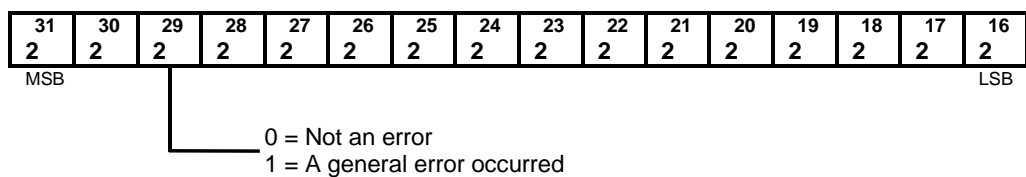

Carrying out the Data check service (08 HEX) transfers the error status to the master as an answer and this defines the error in more detail:

IN data relative to master:

Relative word address "2"

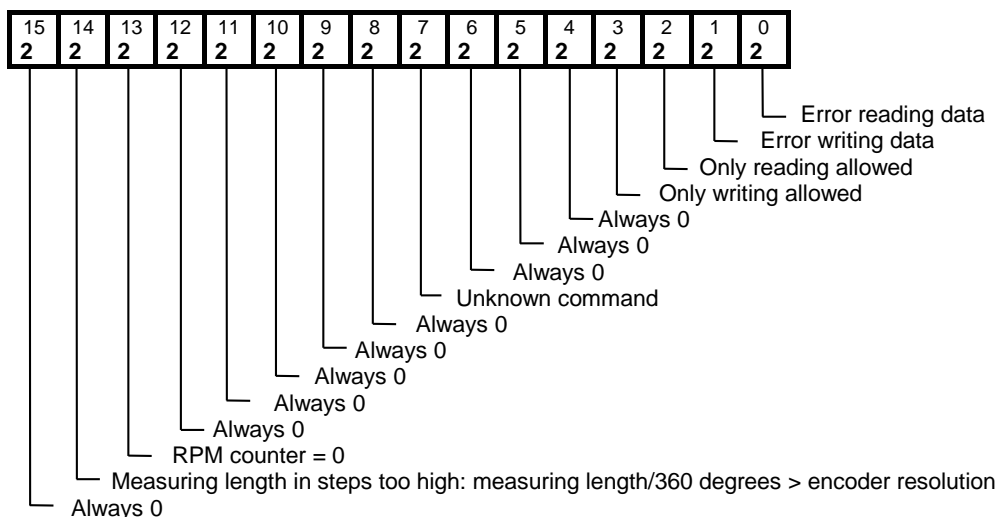

Warning

As soon as error bit 2^{29} is set, you must ensure that appropriate measures are taken to prevent injuries to people or damage to property, e.g. stopping the appropriate axis or system.

If necessary, you must force an **EMERGENCY STOP**.

2 Transportation/Commissioning

2.1 Transportation/Storage

Transportation Information

Do not drop encoders or subject them to excessive jolting!

The device contains an optical system with glass elements.

Use only the original packaging material!

Incorrect packaging material can cause damage to the device in transit.

Storage

Storage temperature: -30 to +80 °C

Store in a cool place.

2.2 Technical Data

2.2.1 Electrical Characteristic Data

Operating voltage:	11-27 V DC (\pm 5% residual ripple)
Max. current consumption:	< 350 mA at 11 V DC, < 150 mA at 27 V DC
Output capacity:	24-bit (25-bit optional)
Resolution:	4096 steps/rev (12-bit)
Option:	8192 steps/rev (13-bit)
Measuring range:	4096 revolutions (12-bit)
Output code:	Programmable (binary, Gray)
Baud rate:	300 kbps net, 500 kbps gross (including control and status bytes)
Data refresh:	0.5 ms
Encoder interface:	Two-wire remote bus for INTERBUS-S, RS422 with galvanic isolation
Ident number:	51 dec.
Special features:	Programming the following parameters via the INTERBUS-S: <ul style="list-style-type: none"> - Direction of rotation - Measuring length in steps - Measuring length in revolutions - Preset adjustment - Code - SSI interface parameters
SSI-OUT data interface	
Clock input:	Optocoupler
Data output:	RS422 (two-wire)
Clock rate:	80 kHz-1 MHz
Code:	Programmable (binary, Gray)
Number of data bits:	Programmable(8-32)
Operating temperature range:	0 to +60 °C

2.2.2 Mechanical Characteristic Data

Mechanically permissible speed:	6000 RPM
Permissible shaft loading:	40 N axial, 60 N radial (at end of shaft)
Minimum bearing lifetime:	3.9 x 10 ¹⁰ revolutions at:
Operating speed:	3000 RPM
Shaft loading:.....	20 N axial, 30 N radial (at end of shaft)
Operating temperature:	60° C
Max. angular acceleration:	≤ 10 ⁴ rad/s ²
Moment of inertia:	2.5 x 10 ⁻⁶ kg m ²
Starting torque at 20 °C:	2 Ncm
Vibration loading (50-2000 Hz):	≤ 100 m/s ²
Shock loading (11 ms):	≤ 1000 m/s ²

2.2.3 Pin Assignments

Explanation of Terms:

CE65:	Compact Encoder with diameter of 65 mm
MINI-COMBICON:	Phoenix MINI-COMBICON connector, 8A/125V, 3.5 mm grid
US:	Supply voltage
US input:	1-level > +8V, 0-level < +2V, up to $\pm 35V$, 5 k Ω
TTL input:	1-level > +2.0V, 0-level < +0.8V, up to $\pm 35V$, 5 k Ω
TTL output:	1-level > +2.0V, 0-level < +0.8V, up to 40mA
Opto input:	Optocoupler for cable transmitter or TTL differential signal
GNDI/GND:	Data reference potentials that are galvanically isolated from one another

X1 - MINI-COMBICON 6-pin, REMOTE IN bus

Pin 1	DO inverted
Pin 2	DO
Pin 3	DI inverted
Pin 4	DI
Pin 5	GNDI (data reference potential from predecessor)
Pin 6	Opto input for negative SSI clock

X2 - MINI-COMBICON 5-pin

Pin 1	Opto input for positive SSI clock
Pin 2	TTL output for negative SSI data
Pin 3	TTL output for positive SSI data
Pin 4	0V supply
Pin 5	US supply

X3 - MINI-COMBICON 6-pin, REMOTE OUT bus

Pin 1	DO inverted
Pin 2	DO
Pin 3	DI inverted
Pin 4	DI
Pin 5	GND (data reference potential for successor)
Pin 6	RBST inverted

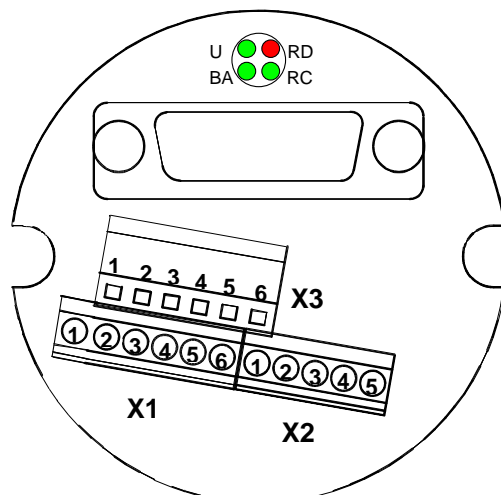

i

Information about Pin Assignments

If the encoder is the last node in the ring, you must wire connector X1 for the incoming remote bus interface and connector X2 for the encoder supply voltage (connector X3 is not wired).

If there are additional nodes in the ring after the encoder, you must additionally wire connector X3 for the remote out interface to the subsequent node.

For the subsequent node to be detected, you must insert a jumper between PIN5 and PIN6 on connector X3.

Optical indications

LED RD (red) Following IBS-Interface is disconnected

LED RC (green) Remote-Control

LED U (green) SUP1 Supply-Voltage

LED BA (green) Interbus-S active

2.3 Assembly

Drive of the Encoder Shaft

Series CE encoders are connected to the drive shaft by an elastic coupling which takes up deviations in the axial and radial directions between the encoder and the drive shaft. This prevents excessive bearing loading. You can order couplings on request.

Flange Fixing

The centring collar with fit f7 centres the encoder to the shaft. Fixing to the machine is by means of three screws in the flange (Figure 1).

Clamping Bracket Fixing

The centring collar with fit f7 centres the encoder to the shaft. Fixing of the encoder is by means of two clamping brackets (Figure 2).

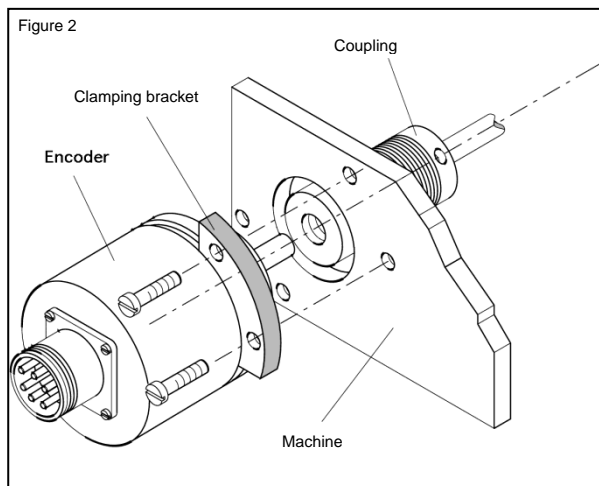
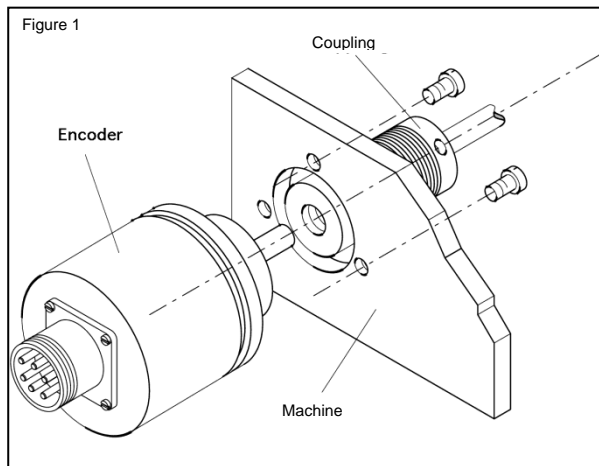

2.4 Commissioning (Rotary Encoder)

2.4.1 Encoder Interface (INTERBUS-S)

The CE-65-M absolute encoder with INTERBUS-S interface is designed as a remote bus module with 32 I/O data. This makes it easy to integrate in the bus ring in the same way as a PHOENIX-CONTACT bus terminal. To ensure that the protocol meets INTERBUS-S requirements, an SYPI (serial microprocessor interface) is integrated between the CE-65-M absolute encoder and the INTERBUS-S. The SYPI is an INTERBUS-S protocol chip developed by PHOENIX-CONTACT which carries out the following functions:

- BUS interfacing: Directions of reception and transmission
- CRC check
- Preset
- Transfer protocol
etc.

i *Note*

At programming, data is exchanged between the encoder and the master in binary form.

2.4.1.1 Mapping of Encoder Data in the Master (Controller)

In the master, the encoder data occupies two-word addresses for IN-data and two-word addresses for OUT-data. The position of the data in the controller depends on the physical or logical position of the encoder within the ring. For detailed information, refer to the manual of the master (controller) used. The encoder should be considered to be a PHOENIX I/O bus terminal and the system processes it as such.

Position of the Encoder Data Within the Two-Word Addresses

OUT-data relative to the master:

Relative word address "1"

31	30	29	28	27	26	25	24	23	22	21	20	19	18	17	16
2	2	2	2	2	2	2	2	2	2	2	2	2	2	2	2

MSB LSB

OUT-data relative to the master:

Relative word address "2"

15	14	13	12	11	10	9	8	7	6	5	4	3	2	1	0
2	2	2	2	2	2	2	2	2	2	2	2	2	2	2	2

MSB LSB

IN-data relative to the master:

Relative word address "1"

31	30	29	28	27	26	25	24	23	22	21	20	19	18	17	16
2	2	2	2	2	2	2	2	2	2	2	2	2	2	2	2

MSB LSB

IN-data relative to the master:

Relative word address "2"

15	14	13	12	11	10	9	8	7	6	5	4	3	2	1	0
2	2	2	2	2	2	2	2	2	2	2	2	2	2	2	2

MSB LSB

Meaning of the OUT-Data (Data from the Master to the Encoder)

Normal Mode:

Service bit 2^{31} is set to "0".
 OUT-data that the master outputs to the encoder does not have any effect and the encoder does not accept it.
 As a result, in normal mode the encoder only outputs its current position data.

Service Mode:

Service bit 2^{31} is set to "1".
 The encoder carries out the master's requested service (e.g. write direction of rotation or read programmed direction of rotation).
 The system evaluates or ignores the remaining OUT-data 2^{23} to 2^0 in dependence on the requested service.

Bit 2^{31} :	Service bit	0 = Normal mode 1 = Service mode
Bit 2^{30} :	Read-write bit	0 = Read data 1 = Write data
Bit 2^{29} :	Error bit	1 = Error
Bit 2^{28} :	Reserve	Always 0
Bit 2^{27} to bit 2^{24} :	Service	
Bit 2^{23} to bit 2^0 :	Data for service if bit $2^{30} = 1$, otherwise meaningless	

Meaning of the IN-Data (Data from the Encoder to the Master)

Normal Mode:

The encoder outputs the current position data and writes it to bits 2^{23} to 2^0 . Bits 2^{31} to 2^{24} are "0" unless there is an error; in this case, error bit $2^{29} = "1"$.

Service Mode:

If the master writes data (read-write bit = 1), the system returns the OUT-data to the IN-data (bits 2^{31} to 2^0).
 If the master reads data (read-write bit = 0), bits 2^{23} to 2^0 contain the requested data and bits 2^{31} to 2^{24} contain the acknowledgement of the requested service.

If the system could not carry out the service without errors, the error bit is "0". It is only possible to clear a set error bit by carrying out a data check service.

3 Parameter Programming (Operation)

3.1 Callable Services

The system processes all service requests from the host to the encoder by means of a handshake of the service bit.

Handshake of service bit 2^{31}

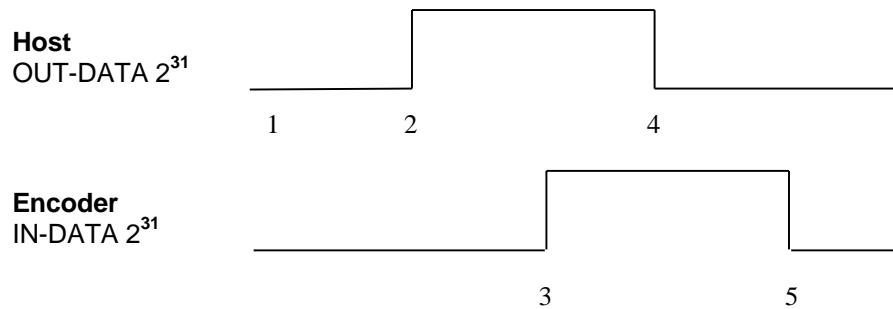

1. The host is in normal mode, service bit 2^{31} is 0.
The IN-data contains the encoder's actual position.

2. The host outputs the data and the service number and sets the service bit to 1.

Note:

To guarantee data consistency between the commissioning card and the PLC, the data and the service number must be output first. One PLC cycle later, the service bit must be set from 0 to 1.

With a read service, OUT data 2^{23} to 2^0 is meaningless.

3. The encoder detects and processes the service request, provides the appropriate data and reports back to the host system by setting service bit 2^{31} . With a read service, the system returns the OUT data to the IN data.

4. The host system detects execution and ends the service request.
The system resets service bit 2^{31} and switches back to normal mode.

5. The encoder also detects the end of the service request and also switches to normal mode by resetting service bit 2^{31} . Afterwards, the system continues with the encoder's actual value output.

3.1.1 Direction of Counting/Code – Service 01 Hex

Service Request from Master (OUT Data)

2^{31} to 2^{24}	2^{23} to 2^{16}	2^{15} to 2^8	2^7 to 2^0	
a) 81 Hex	No effect	No effect	No effect	Read data
b) C1 Hex	0 or 1 (Meaningless)	0 or 1 0 = Binary ≠ 0 = Gray	* 0 or 1 0 = CW rising ≠ 0 = CW falling	Write data

* 0 = Data rising clockwise looking towards the shaft
 ≠ 0 = Data falling clockwise looking towards the shaft

Service Feedback Message from Encoder (IN Data)

2^{31} to 2^{24}	2^{23} to 2^0	
a) 81 Hex	0 or 1	Depending on programming
b) C1 Hex	0 or 1	Depending on programming

3.1.2 Measuring Length in Steps – Service 02 Hex

Measuring length in steps = (resolution/360 degrees x measuring range in revs) -1

Service Request from Master (OUT Data)

2^{31} to 2^{24}	2^{23} to 2^0	
a) 82 Hex	No effect	Read data
b) C2 Hex	FF FF FF Hex to 10 Hex	Write data

Service Feedback Message from Encoder (IN Data)

2^{31} to 2^{24}	2^{23} to 2^0	
a) 82 Hex	FF FF FF Hex to 10 Hex	Depending on programming
b) C2 Hex	FF FF FF Hex to 10 Hex	Depending on programming

3.1.3 Measuring Length in Revolutions Numerator – Service 03 Hex

Service Request from Master (OUT Data)

2^{31} to 2^{24}	2^{23} to 2^0	
a) 83 Hex	No effect	Read data
b) C3 Hex	00 FF FF Hex to 1 Hex	Write data

Service Feedback Message from Encoder (IN Data)

2^{31} to 2^{24}	2^{23} to 2^0	
a) 83 Hex	00 FF FF Hex to 1 Hex	Depending on programming
b) C3 Hex	00 FF FF Hex to 1 Hex	Depending on service request

3.1.4 Preset Adjustment – Service 06 Hex

Service Request from Master (OUT Data)

2^{31} to 2^{24}	2^{23} to 2^0	
C6 Hex	Measuring length in steps to 0 Hex	Write data

Service Feedback Message from Encoder (IN Data)

2^{31} to 2^{24}	2^{23} to 2^0	
C6 Hex	Measuring length in steps to 0 Hex	Depending on service request

3.1.5 Data Check – Service 08 Hex

Service Request from Master (OUT Data)

2^{31} to 2^{24}	2^{23} to 2^0	
88 Hex	No effect	Read data

Service Feedback Message from Encoder (IN Data)

2^{31} to 2^{24}	2^{23} to 2^0	
88 Hex	2^{23} to 2^{16} always "0"	2^{15} to 2^0 error status

3.1.6 Measuring Length in Revolutions Denominator – Service 09 Hex

Service Request from Master (OUT Data)

2^{31} to 2^{24}	2^{23} to 2^0	
a) 89 Hex	No effect	Read data
b) C9 Hex	0000 63 Hex to 1 Hex	Write data

Service Feedback Message from Encoder (IN Data)

2^{31} to 2^{24}	2^{23} to 2^0	
a) 89 Hex	0000 63 Hex to 1 Hex	Depending on programming
b) C9 Hex	0000 63 Hex to 1 Hex	Depending on service request

3.1.7 SSI-OUT Data Interface

3.1.7.1 SSI Characteristic Values – Service 0D Hex

Service Request from Master (OUT Data)

2^{31} to 2^{24}	2^{23} to 2^{16}	2^{15} to 2^8	2^7 to 2^0	
a) 8D Hex	No effect	No effect	No effect	Read data
b) CD Hex	0 or 1 0 = without repet. ≠ 0 = with repet.	0 or 1 0 = Binary ≠ 0 = Gray	Number of data bits 08 to 20 Hex Valid starting CW 41/ 97: Entry 1F hex = AK-40 compatible	Write data

Service Feedback Message from Encoder (IN Data)

2^{31} to 2^{24}	2^{23} to 2^{16}	2^{15} to 2^8	2^7 to 2^0	
a) 8D Hex	0 or 1	0 or 1	Number of data bits 08 to 20 Hex	Depending on programming
b) CD Hex	0 or 1 0 = without repet. ≠ 0 = with repet.	0 or 1 0 = Binary ≠ 0 = Gray	Number of data bits 08 to 20 Hex	Depending on service request

3.2 Brief Description of Executable Services

3.2.1 Direction of Counting/Code – Service 01 Hex

Here, you specify the direction of counting and the encoder's code:

Value 0 Hex (2^7 to 2^0) = encoder position rising clockwise (looking towards shaft)

Value $\neq 0$ (2^7 to 2^0) = encoder position falling clockwise (looking towards shaft)

Value 0 Hex (2^{15} to 2^8) = data output to the INTERBUS-S in binary code

Value $\neq 0$ (2^{15} to 2^8) = data output to the INTERBUS-S in Gray code

Reading and writing are possible.

The value range in each case is 0 to FF Hex.

3.2.2 Measuring Length in Steps – Service 02 Hex

Here, you specify the total length in steps:

Measuring length in steps = (measuring length / 360 degrees x measuring length in revs) - 1

Reading and writing are possible.

The value range is 10 Hex to FF FF FF Hex.

3.2.3 Measuring Length in Revolutions (Numerator) – Service 03 Hex, Measuring Length in Revolutions (Denominator) – Service 09 Hex

Here, you specify the number of revolutions that the encoder carries out within the total number of steps.

If the number of revolutions is an integer, you should always program the denominator to the value "1".

If the number of revolutions is a decimal number, program the denominator with the digits after the decimal point.

Example:

The encoder is intended to resolve 3.5 revolutions.

⇒ Revolutions numerator = 35 (service 03 Hex)

⇒ Revolutions denominator = 10 (service 09 Hex)

If you program a number of revolutions that is not a power of two, the zero point can be lost if the encoder traverses more than 512 revolutions in a deenergized state.

Reading and writing are possible.

Value range of numerator: 1 - FF FF Hex

Value range of denominator: 1 - 63 Hex

3.2.4 Preset Adjustment – Service 06 Hex

Using preset adjustment, you can adjust the encoder to a specific value via the INTERBUS-S ring.

Only writing is possible.

Value range: 0 to the programmed measuring length in steps (value from service 02 Hex).

3.2.5 Data Check – Service 08 Hex

After programming the encoder, you must call the data check service. This call checks the validity of the programmed data and accepts it. Without this call, the encoder continues to run with the old parameters until you switch the power off and on again.

Only reading is possible.

On 2^0 to 2^{15} of the IN data the master receives the error status as the response.

Bits 2^{16} to 2^{23} of the IN data are "0".

Bits 2^{24} to 2^{31} of the IN data feed back the requested service.

Error Status

2^0	Error reading data
2^1	Error writing data
2^2	Only reading allowed
2^3	Only writing allowed
2^4	Always 0
2^5	Always 0
2^6	Always 0
2^7	Unknown command
2^8	Always 0
2^9	Always 0
2^{10}	Always 0
2^{11}	Always 0
2^{12}	Always 0
2^{13}	Revolutions numerator = 0
2^{14}	Measuring length in steps is too high. Measuring length/360 degrees > encoder resolution same as on encoder's rating plate
2^{15}	Always 0

If an error occurs at execution of a service (error bit set in encoder's service feedback message), you can determine the error exactly by carrying out the data check service.

3.2.6 SSI-OUT Data Interface

Data Transfer

At rest, Data+ and Clock+ are +5V (High). Data transfer starts with the MSB and is initiated by the first falling clock edge. Data is changed by a positive clock edge. Depending on the receiver, data is accepted with a rising or a falling edge.

When the clock sequence is over, the system keeps the data lines at 0V (Low) for the duration of the mono period, t_M . Time t_M is set to 20 μ s and it determines the lowest transfer frequency of approximately 50 kHz. The upper limit frequency results from the total of all the signal propagation delays and is approximately 1.1 MHz.

3.2.6.1 SSI Characteristic Values – Service 0D Hex

Reading and writing are possible.

Number of Data Bits

Using this parameter, you can shift data anywhere within the number of clock pulses. The data can be transferred right- or left-justified and with or without leading zeros. You generate leading zeros by generating a higher number of data bits than would normally be necessary for the encoder.

Value range: 08 to 20 Hex

Note (valid starting CW 41 / 97)

By programming the number of data bits to 31 (1F hex) the SSI-output format will be set automatic to the AK-40 data format:

31 data bits; binary; data bit 32 = Parity odd

Code

The code is a method for forming digital numbers. A code word is a bit pattern that expresses a numerical value. The code describes the assignments of code words and their values.

In the case of multi-step codes, changing the numerical value by 1 results in a new code word in which several bits are different from the old one. With single-step codes, only one bit changes in the code word in this case.

With decadic codes, four bits in each case are grouped together to one decimal digit.

The following codes are used:

Binary code (multi-step code)

Gray code (single-step code)

Value range: 00 to FF Hex

Repetition

Using the Repetition parameter, you choose whether the data bits in long pulse bundles are to be repeated every 26 pulses. In this connection, the system automatically sets the number of data bits to 24.

Application: Easy determination of transfer disturbances.

Value range: 00 to FF Hex

3.3 Example of Programming the Measuring Length in Steps

Specifications:

Resolution/360 degrees	= 3E8 Hex
Measuring length in revolutions numerator	= 0A Hex
Measuring length in revolutions denominator	= 1 Hex

$$\begin{aligned}
 \text{Measuring length in steps} &= \left[\text{Resolution/360 degrees} \times \frac{\text{Measuring length in revolutions numerator}}{\text{Measuring length in revolutions denominator}} \right] - 1 \\
 &= 3E8 \times \frac{0A}{1} - 1 \\
 &= \underline{\underline{27\ 0F\ \text{Hex}}}
 \end{aligned}$$

Carry out the following steps:

Service Request from Master (OUT Data)

2^{31} to 2^{24}	2^{23} to 2^0	
C2 Hex	00 27 0F Hex	Write data/start of handshake

Service Feedback Message from Encoder (IN Data)

2^{31} to 2^{24}	2^{23} to 2^0	
C2 Hex	00 27 0F Hex	Data feedback message/confirm handshake

End Service Request from Master (OUT Data)

2^{31} to 2^{24}	2^{23} to 2^0	
Bit 2^{31} to "0"	Rest have no effect/deactivate handshake	

Service Feedback Message from Encoder (IN Data)

2^{31} to 2^{24}	2^{23} to 2^0	
Value "0"	Current encoder position/deactivate handshake	

For the system to accept the new Measuring length in steps parameter, a data check must be carried out first. If you still have other parameters to program, do not carry out the data check until you have completed programming them.

4 Disturbances

4.1 Causes of Faults and Remedies

Disturbance	Cause	Remedy
Encoder step changes	Loose contacts in the wiring	Check all the cabling and wiring used for connecting the encoder.
	Severe vibrations	"Shock modules" are used to cushion vibrations shocks and jolts on presses, for example. If the fault keeps occurring despite these measures, you must replace the encoder.
	Electrical disturbances	Insulating flanges and couplings and cables with twisted-pair wires for data and supply are useful against electrical disturbances. The cable screens should be grounded on both ends. You should only ground the screen on one end in the switching cabinet if the machine ground has more disturbances compared to the switching cabinet ground.
	Excessive axial and radial loading of the shaft or a sampling defect.	Plastic couplings prevent mechanical loading of the shaft. If the fault keeps occurring despite these measures, you must replace the encoder.
Error reading data (Status bit $2^0=1$)	Defective memory area in the EEPROM	If the error occurs when you try to execute the service again, you must replace the encoder.
Error writing data (Status bit $2^1=1$)	Defective memory area in the EEPROM	If the error occurs when you try to execute the service again, you must replace the encoder.
Only reading allowed (Status bit $2^2=1$)	The system tried to carry out a write command.	Set bit 2^{30} (read-write bit) to 0.
Only writing allowed (Status bit $2^3=1$)	The system tried to carry out a read command.	Set bit 2^{30} (read-write bit) to 1.
Unknown command (Status bit $2^7=1$)	You entered the wrong service number.	Check the executed service number and correct it.
Revolutions numerator = 0 (Status bit $2^{13}=1$)	You entered a "0" when programming the measuring length in revolutions numerator (service 03 HEX).	Allowed value range: 00 FF FF HEX to 1 HEX
Measuring length in steps too high (Status bit $2^{14}=1$)	The revolutions fraction (numerator/denominator) was programmed too low.	The number of steps per revolution must not exceed the encoder resolution stated on the rating place. Program a higher setting for the revolutions fraction (numerator/denominator).