

# FUJI Power Semiconductors

## IGBT Modules

IGBT 6-pack/4-pack Page 1

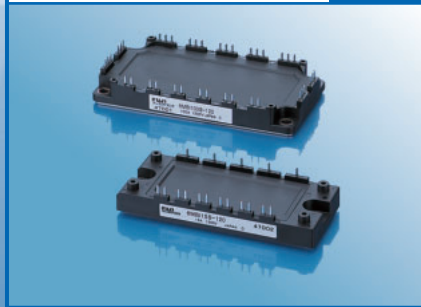

IGBT High Power 6-pack Page 3



IGBT PIM Page 4



IGBT Standard 2-pack/1-pack Page 7



IGBT IPM Page 10

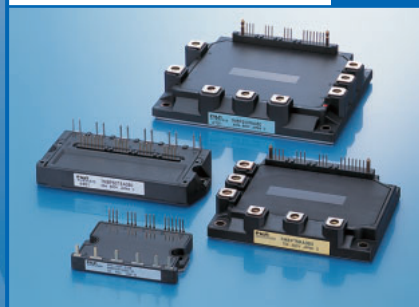

IGBT Discrettes Page 12

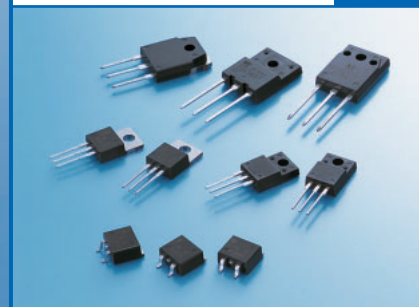

# IGBT 6-pack/4-pack

mm

Ic

**600V**

**1200V**

**Gen. 3, Gen. 4  
Planar-PT**

**Gen. 4  
Planar-NPT**

**Gen. 4  
Planar-NPT**

**1**

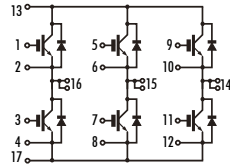
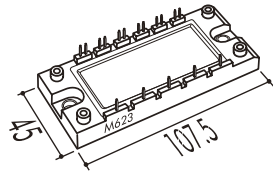

**10A**  
**15A**  
**25A**  
**35A**  
**50A**

6MBI10S-120  
6MBI15S-120  
6MBI25S-120  
6MBI35S-120  
6MBI50S-120

**2**

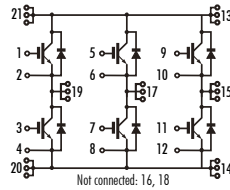
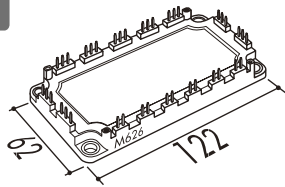

**75A**  
**100A**

6MBI75S-060  
6MBI100S-060

6MBI75S-120  
6MBI100S-120

**3**

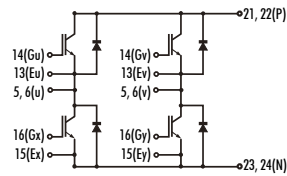
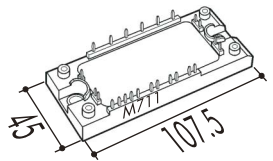

**75A**  
**100A**

4MBI75T-060  
4MBI100T-060

**4**

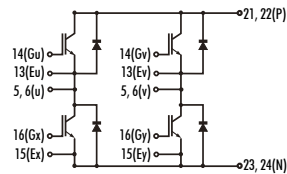
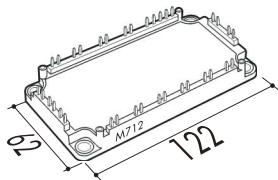

**150A**  
**200A**

4MBI150T-060  
4MBI200T-060

Standard

# IGBT 6-pack

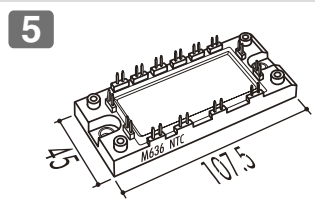
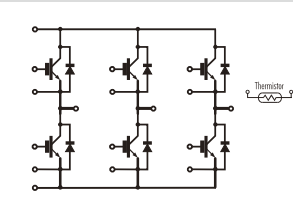
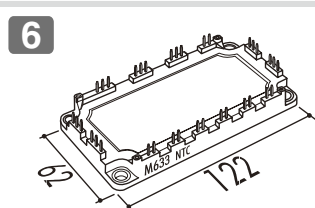
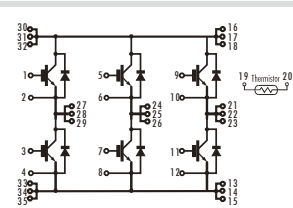
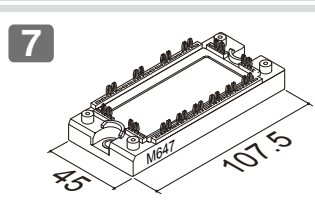
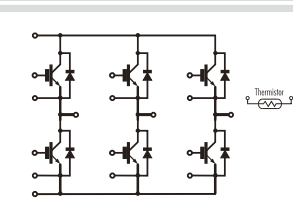
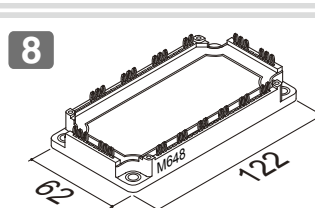
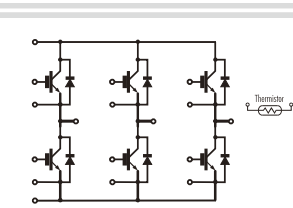
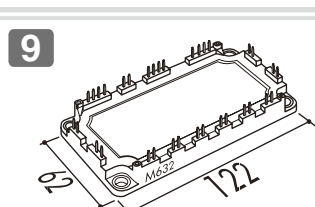
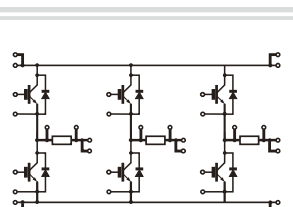
		600V		1200V		1700V
		Gen. 5 Planar-NPT	Gen. 6 Trench-FS	Gen. 5 Trench-FS	Gen. 6 Trench-FS	Gen. 5 Trench-FS
With NTC	<b>5</b>			<b>Ic</b>		
				<b>35A</b>	6MBI35U4A-120	
				<b>50A</b>		6MBI50VA-120-50 *
				<b>75A</b>	6MBI75U2A-060	6MBI75VA-120-50 *
				<b>100A</b>		6MBI100VA-120-50 *
With NTC	<b>6</b>			<b>75A</b>	6MBI75U4B-120	
				<b>100A</b>	6MBI100U2B-060	6MBI100U4B-170
				<b>150A</b>	6MBI150U2B-060	6MBI150VB-120-50 *
				<b>180A</b>		6MBI180VB-120-50 *
With NTC	<b>7</b>			<b>50A</b>		6MBI50VW-120-50 *
				<b>75A</b>	6MBI75VW-060-50 *	6MBI75VW-120-50 *
				<b>100A</b>	6MBI100VW-060-50 *	6MBI100VW-120-50 *
With NTC	<b>8</b>			<b>100A</b>		6MBI100VX-120-50 *
				<b>150A</b>	6MBI150VX-060-50 *	6MBI150VX-120-50 *
				<b>180A</b>		6MBI180VX-120-50 *
With shunts	<b>9</b>			<b>75A</b>	6MBI75UC-120	
				<b>100A</b>	6MBI100UC-120	

\* Under development

# IGBT 6-pack

mm

Ic

**1200V**

**1700V**

**Gen. 5  
Trench-FS**

**Gen. 5  
Trench-FS**

**225A**

6MBI225U4-120

6MBI225U4-170

**300A**

6MBI300U4-120

6MBI300U4-170

**450A**

6MBI450U4-120

6MBI450U4-170

High power 6-pack

10

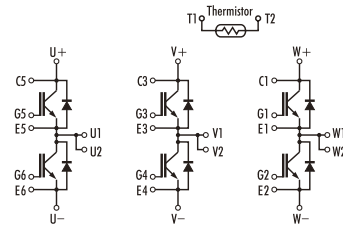
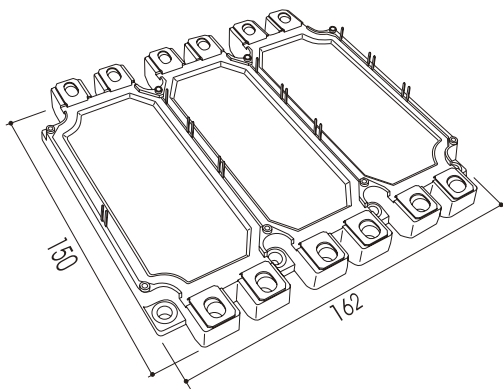

**IGBT PIM (Power Integrated Module)** mm

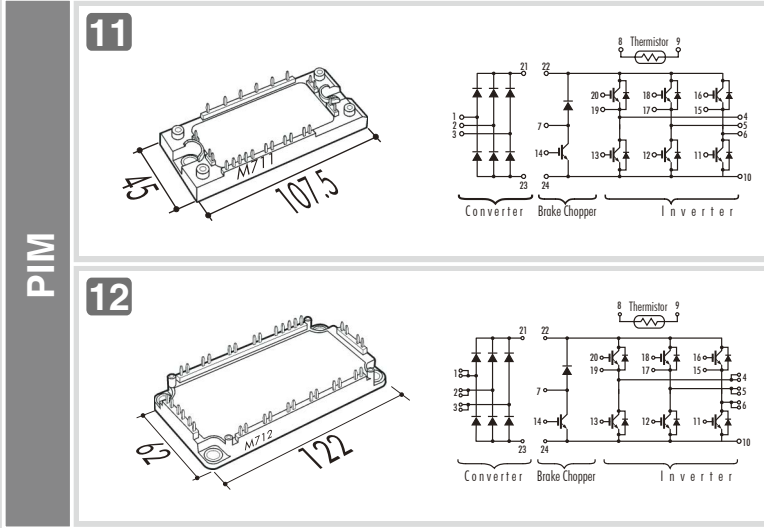

Ic	600V		1200V	
	Gen. 4 Planar-PT	Gen. 5 Trench/ Planar-NPT	Gen. 4 Planar-NPT	Gen. 5 Trench-FS
<b>10A</b>			7MBR10SA120	
<b>15A</b>			7MBR15SA120	
<b>25A</b>			7MBR25SA120	7MBR25UA120
<b>30A</b>	7MBR30SA060	7MBR30U2A060		
<b>35A</b>				7MBR35UA120
<b>50A</b>	7MBR50SA060	7MBR50U2A060		7MBR50UA120
<b>35A</b>			7MBR35SB120	7MBR35UB120
<b>50A</b>	7MBR50SB060		7MBR50SB120	7MBR50UB120
<b>75A</b>	7MBR75SB060	7MBR75U2B060		7MBR75U4B120
<b>100A</b>	7MBR100SB060	7MBR100U2B060		7MBR100U4B120

# IGBT PIM (Power Integrated Module) mm

PIM

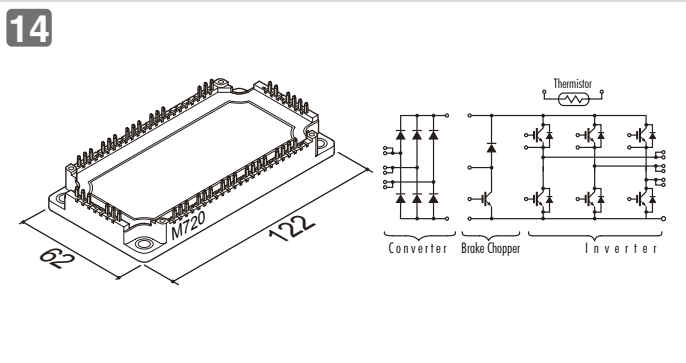
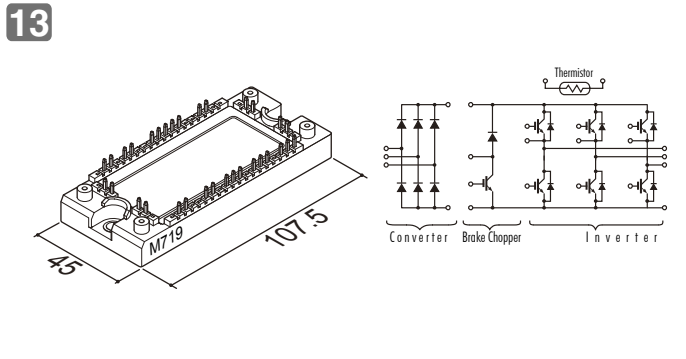

**Ic**

**25A**

**35A**

**50A**

**75A**

**100A**

**50A**

**75A**

**100A**

**150A**

**600V**

**Gen. 6  
Trench-FS**

7MBR50VP060-50 \*

7MBR75VP060-50 \*

7MBR100VP060-50 \*

7MBR100VR060-50 \*

7MBR150VR060-50 \*

**1200V**

**Gen. 6  
Trench-FS**

7MBR25VM120-50 \*  
7MBR25VP120-50 \*

7MBR35VM120-50 \*  
7MBR35VP120-50 \*

7MBR50VM120-50 \*  
7MBR50VP120-50 \*

7MBR50VN120-50 \*  
7MBR50VR120-50 \*

7MBR75VN120-50 \*  
7MBR75VR120-50 \*

7MBR100VN120-50 \*  
7MBR100VR120-50 \*

7MBR150VN120-50 \*  
7MBR150VR120-50 \*

\* Under development

**In/Out terminal Layout**

7MBR□VM/VN□-50

7MBR□VP/VR□-50

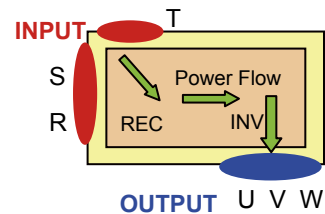
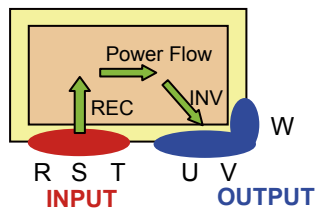

# IGBT PIM (Power Integrated Module) mm

PIM

15

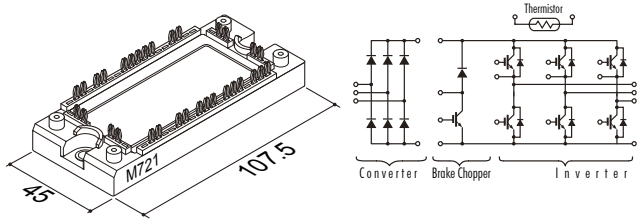

16

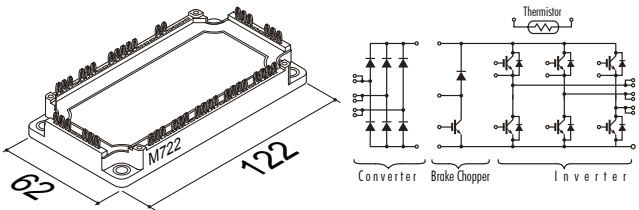

Ic

25A

35A

50A

75A

100A

50A

75A

100A

150A

**600V**

**Gen. 6  
Trench-FS**

7MBR50VY060-50 \*

7MBR75VY060-50 \*

7MBR100VY060-50 \*

7MBR150VZ060-50 \*

**1200V**

**Gen. 6  
Trench-FS**

7MBR25VW120-50 \*  
7MBR25VY120-50 \*

7MBR35VW120-50 \*  
7MBR35VY120-50 \*

7MBR50VW120-50 \*  
7MBR50VY120-50 \*

7MBR50VX120-50 \*  
7MBR50VZ120-50 \*

7MBR75VX120-50 \*  
7MBR75VZ120-50 \*

7MBR100VX120-50 \*  
7MBR100VZ120-50 \*

\* Under development

### In/Out terminal Layout

7MBR□VW/VX□-50

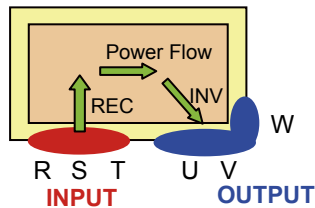

7MBR□VY/VZ□-50

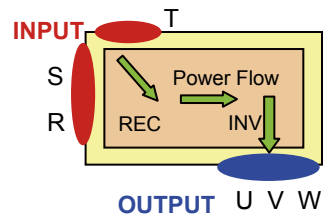

**IGBT Standard 2-pack** mm

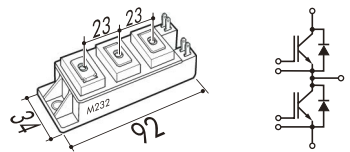
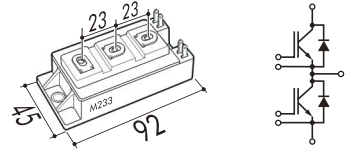
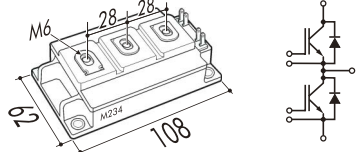
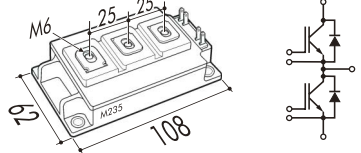
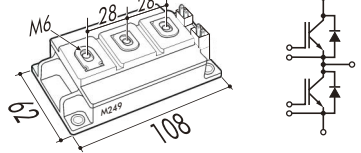
			600V	1200V		1700V
		Ic	Gen. 5 Planar-NPT	Gen. 4 Planar-NPT	Gen. 5 Trench-FS	Gen. 5 Trench-FS
<b>2-pack</b>	<b>17</b> 	50A				
		75A		2MBI75S-120	2MBI75U4A-120	
		100A			2MBI100U4A-120	
		150A	2MBI150U2A-060		2MBI150U4A-120	
		200A	2MBI200U2A-060			
	<b>18</b> 	100A		2MBI100SC-120		
		150A		2MBI150SC-120	2MBI150U4B-120	
		200A			2MBI200U4B-120	
		300A	2MBI300U2B-060			
		400A	2MBI400U2B-060			
	<b>19</b> 	100A		2MBI100S-120		
		150A		2MBI150S-120		
		200A		2MBI200S-120	2MBI200UC-120	
		300A			2MBI300UC-120	
		400A				
	<b>20</b> 	100A				
		150A				
		200A		2MBI200SB-120	2MBI200U4D-120	
		300A			2MBI300U4D-120	
		400A				
<b>21</b> 	100A				2MBI100U4H-170	
	150A			2MBI150U4H-120	2MBI150U4H-170	
	200A			2MBI200U4H-120	2MBI200U4H-170	
	300A			2MBI300U4H-120	2MBI300U4H-170	
	400A			2MBI400U4H-120	2MBI400U4H-170	



## IGBT Standard 2-pack mm

			600V	1200V		1700V				
2-pack	Ic	Diagram	Gen. 5	Gen. 4	Gen. 5	Gen. 6	Gen. 5			
			Planar-NPT	Planar-NPT	Trench-FS	Trench-FS	Trench-FS			
			<b>22</b>		225A 300A 450A 600A			2MBI225U4N-120-50 2MBI300U4N-120-50 2MBI450U4N-120-50	2MBI225VN-120-50 * 2MBI300VN-120-50 * 2MBI450VN-120-50 * 2MBI600VN-120-50 *	2MBI225U4N-170-50 2MBI300U4N-170-50 2MBI450U4N-170-50
			<b>23</b>		225A 300A 450A 600A			2MBI225U4J-120-50 2MBI300U4J-120-50 2MBI450U4J-120-50	2MBI225VJ-120-50 * 2MBI300VJ-120-50 * 2MBI450VJ-120-50 * 2MBI600VJ-120-50 *	
			<b>24</b>		300A 450A 600A		2MBI300S-120	2MBI300U4E-120 2MBI450U4E-120		
<b>25</b>		600A 800A 1200A			2MBI600U4G-120 2MBI800U4G-120 2MBI1200U4G-120		2MBI600U4G-170 2MBI800U4G-170 2MBI1200U4G-170			

\* Under development

# IGBT Standard 1-pack mm

1-pack

26

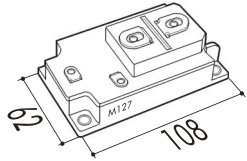

**200A**  
**300A**  
**400A**  
**600A**

1MBI200S-120  
1MBI300S-120  
1MBI400S-120

1MBI300U4-120  
1MBI400U4-120  
1MBI600U4-120

27

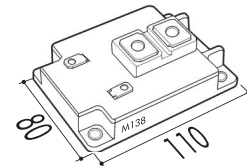

**600A**  
**800A**

1MBI600S-120

1MBI600U4B-120  
1MBI800U4B-120

28

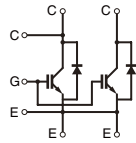
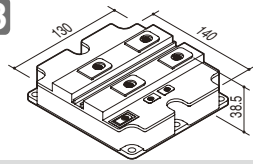

**1200A**  
**1600A**

1MBI1200U4C-120  
1MBI1600U4C-120

1MBI1200U4C-170  
1MBI1600U4C-170

29

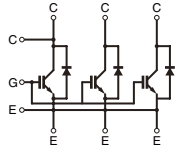
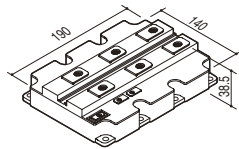

**2400A**  
**3600A**

1MBI2400U4D-120  
1MBI3600U4D-120

1MBI2400U4D-170  
1MBI3600U4D-170

		1200V		1700V
		Gen. 4	Gen. 5	Gen. 5
		Planar-NPT	Trench-FS	Trench-FS
26	200A	1MBI200S-120		
	300A	1MBI300S-120	1MBI300U4-120	
	400A	1MBI400S-120	1MBI400U4-120	
	600A		1MBI600U4-120	
27	600A	1MBI600S-120	1MBI600U4B-120	
	800A		1MBI800U4B-120	
28	1200A		1MBI1200U4C-120	1MBI1200U4C-170
	1600A		1MBI1600U4C-120	1MBI1600U4C-170
29	2400A		1MBI2400U4D-120	1MBI2400U4D-170
	3600A		1MBI3600U4D-120	1MBI3600U4D-170

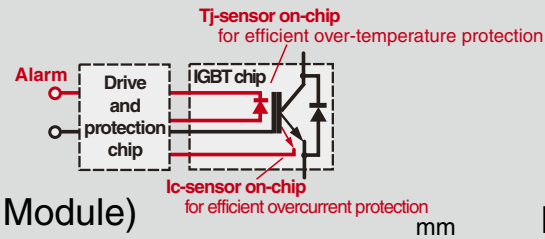

# IGBT IPM (Intelligent Power Module)

	30	31		
Without brake-chopper				
With brake-chopper				
Without brake-chopper				
With brake-chopper				
Without brake-chopper				
With brake-chopper				

Ic	600V		1200V	
	Gen. 3 Planar-PT	Gen. 4 Planar-NPT	Gen. 4 Planar-NPT	Gen. 5 Planar-FS
15A	6MBP15RH060		6MBP15RA120 *	
20A	6MBP20RH060	6MBP20RTA060*		
30A	6MBP30RH060			
25A			7MBP25RSB120	
25A			6MBP25RA120	6MBP25RU2A120
50A	6MBP50RA060	6MBP50RTB060	6MBP50RA120	6MBP50RU2A120
75A	6MBP75RA060	6MBP75RTB060	6MBP75RA120	6MBP75RU2A120
100A	6MBP100RA060	6MBP100RTB060		
150A	6MBP150RA060	6MBP150RTB060		
25A			7MBP25RA120	7MBP25RU2A120
50A	7MBP50RA060	7MBP50RTB060	7MBP50RA120	7MBP50RU2A120
75A	7MBP75RA060	7MBP75RTB060	7MBP75RA120	7MBP75RU2A120
100A	7MBP100RA060	7MBP100RTB060		
150A	7MBP150RA060	7MBP150RTB060		
100A			6MBP100RA120	
150A			6MBP150RA120	
200A	6MBP200RA060			
300A	6MBP300RA060			
100A			7MBP100RA120	
150A			7MBP150RA120	
200A	7MBP200RA060			
300A	7MBP300RA060			

\* The package outline is 31.

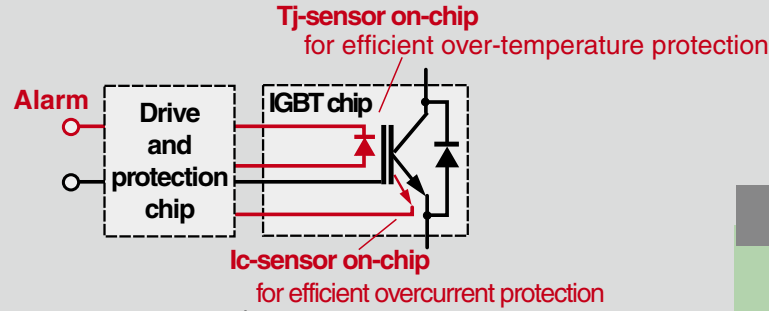

## IGBT IPM (Intelligent Power Module)

mm





	35 With upper alarm output	36 With upper alarm output
Without brake-chopper		
With brake-chopper		

Ic

	600V	1200V
	Gen. 4 Planar-NPT	Gen. 4 Planar-NPT
25A		6MBP25RJ120
50A	6MBP50RTJ060	6MBP50RJ120
75A	6MBP75RTJ060	6MBP75RJ120
100A	6MBP100RTJ060	
150A	6MBP150RTJ060	
25A		7MBP25RJ120
50A	7MBP50RTJ060	7MBP50RJ120
75A	7MBP75RTJ060	7MBP75RJ120
100A	7MBP100RTJ060	
150A	7MBP150RTJ060	
25A		6MBP25TEA120
50A	6MBP50TEA060	6MBP50TEA120
75A	6MBP75TEA060	6MBP75TEA120
100A	6MBP100TEA060	
150A	6MBP150TEA060	
25A		7MBP25TEA120
50A	7MBP50TEA060	7MBP50TEA120
75A	7MBP75TEA060	7MBP75TEA120
100A	7MBP100TEA060	
150A	7MBP150TEA060	

## IGBT Discretes

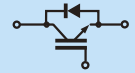
mm

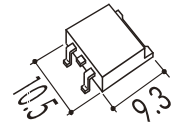
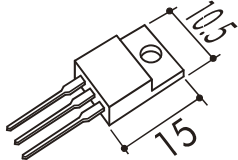
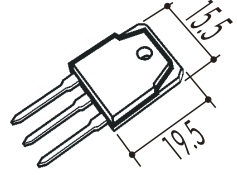
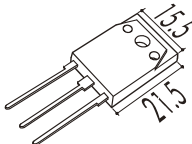
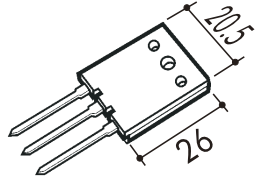
		600V		1200V		
		Planar-PT		Planar-PT		
						
		<b>Ic</b>				
T-pack(S)	<b>37</b>  SMD	5A	1MBG05D-060			
		10A	1MBG10D-060			
TO-220AB	<b>38</b> 	2.5A			1MBC03-120	
		5A	1MBC05D-060	1MBC05-060		
		10A	1MBC10D-060	1MBC10-060		
		15A		1MBC15-060		
TO-3P	<b>39</b> 	2.5A			1MB03D-120	
		5A			1MB05D-120	
		8A				1MB05-120
		10A				1MB08D-120
						1MB08-120
		10A				1MB10D-120
						1MB10-120
TO-247	<b>40</b> 	15A	1MB15D-060			
		20A	1MB20D-060	1MB20-060		
		30A		1MB30-060		
		30A	1MBK30D-060S			
TO-3PL	<b>41</b> 	50A	1MBK50D-060S			
		15A			1MBH15D-120	
		25A			1MBH15-120	
		30A	1MBH30D-060			
		50A	1MBH50D-060	1MBH50-060		
			1MBH50D-060S			
		75A	1MBH75D-060S			

# Package Outlines

mm

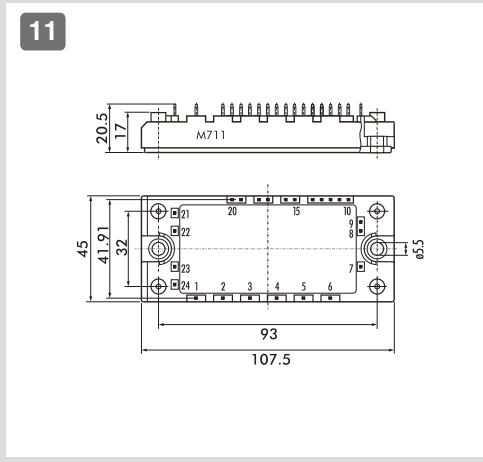
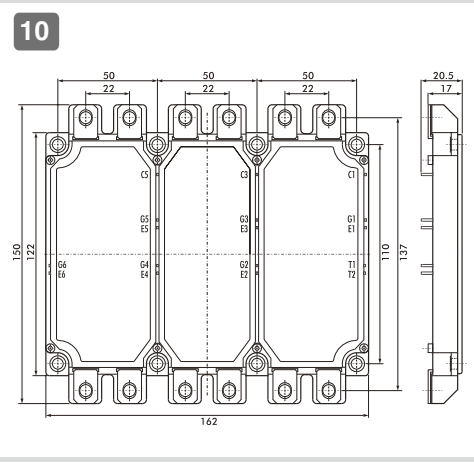
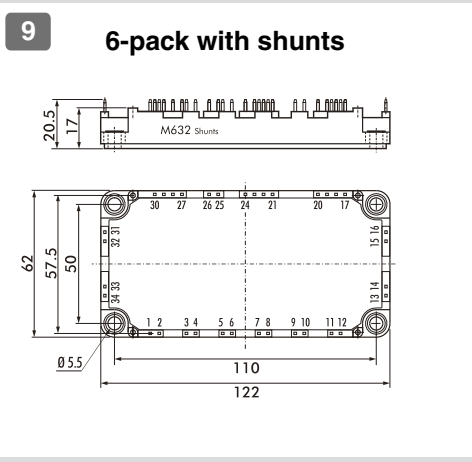
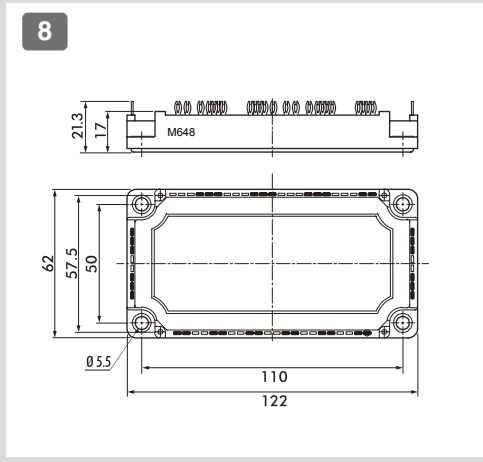
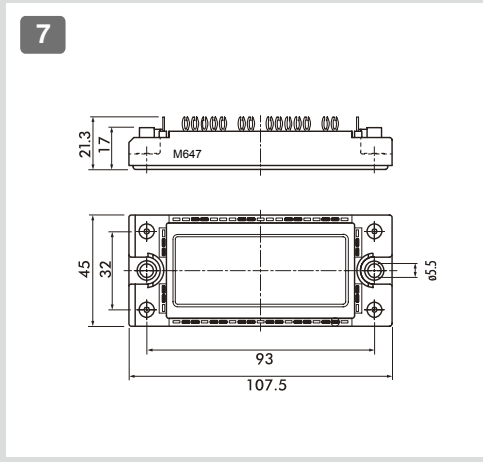
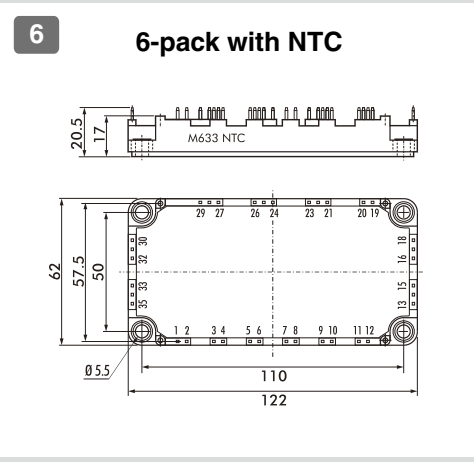
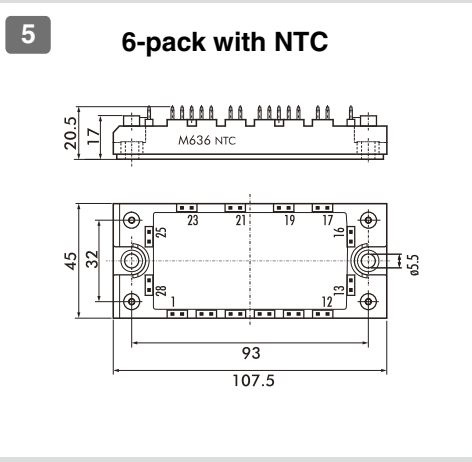
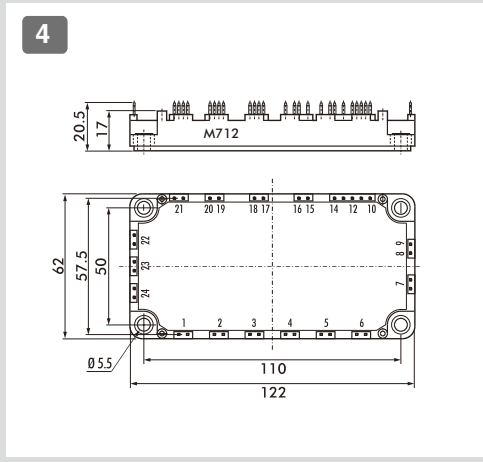
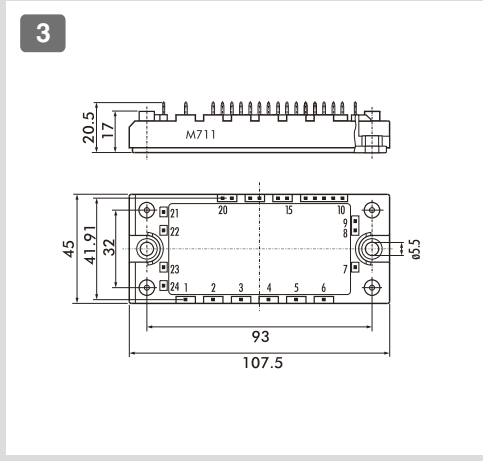
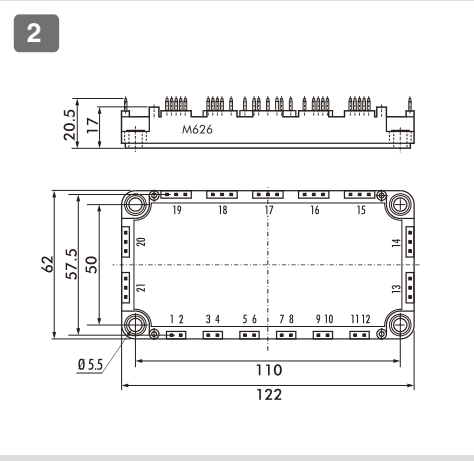
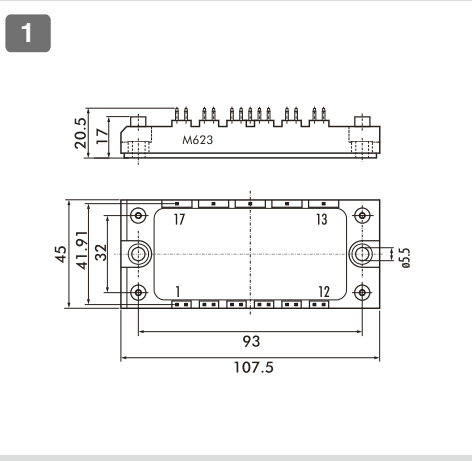

# Package Outlines

mm

12

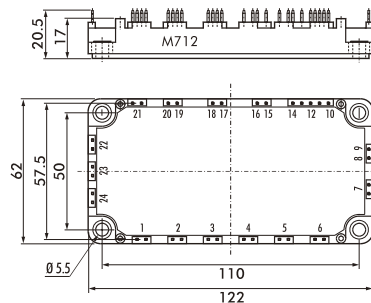

13

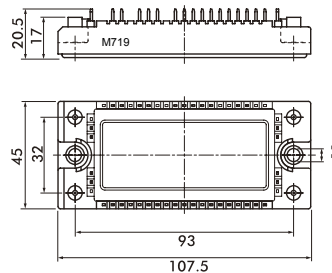

14

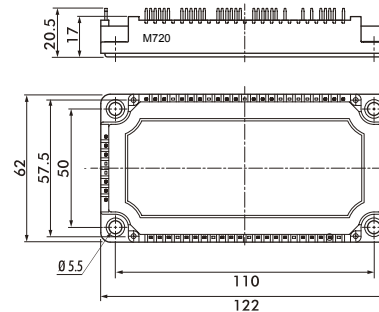

15

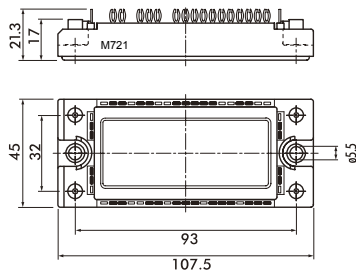

16

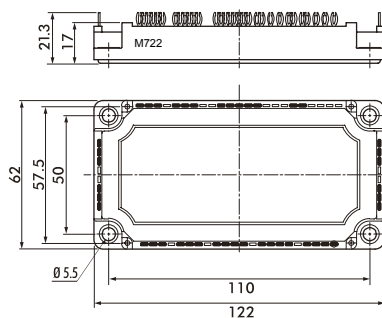

17

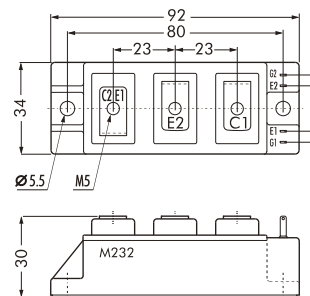

18

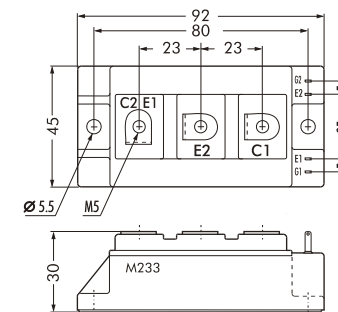

19

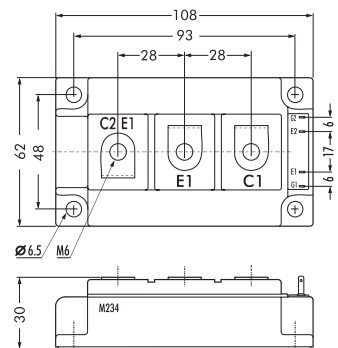

20

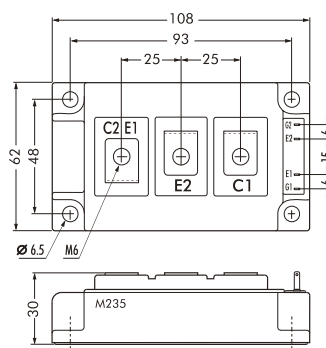

21

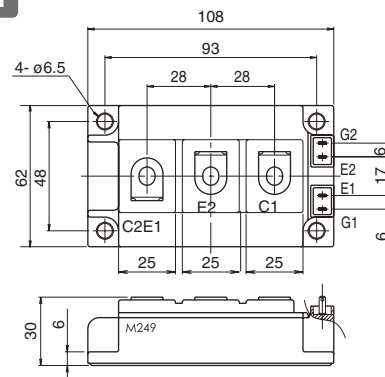

22

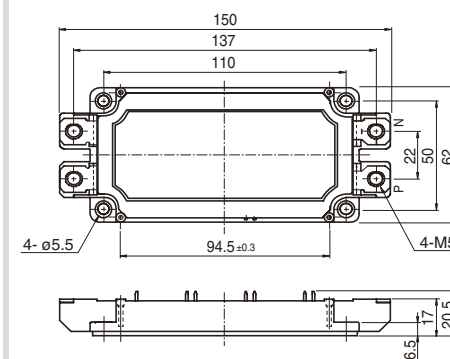

# Package Outlines

23

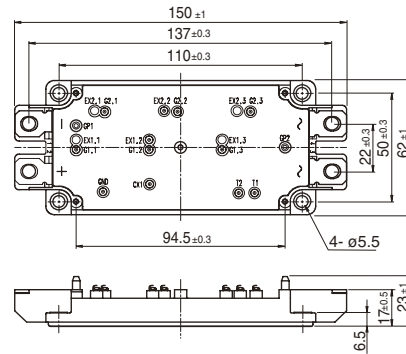

24

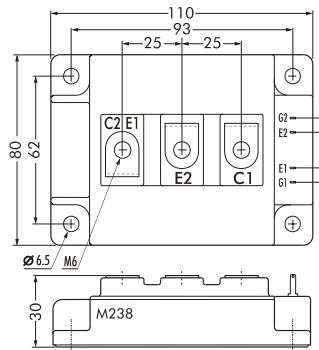

25

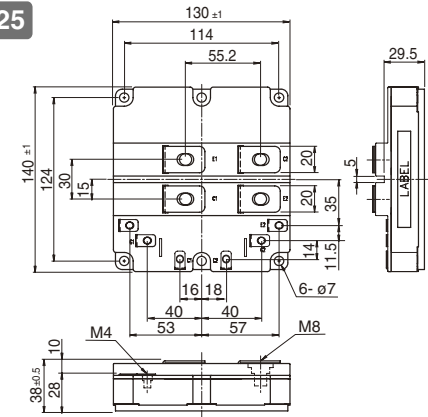

mm

26

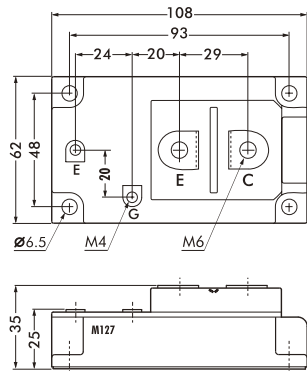

27

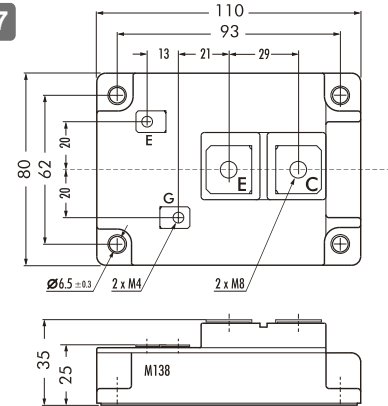

28

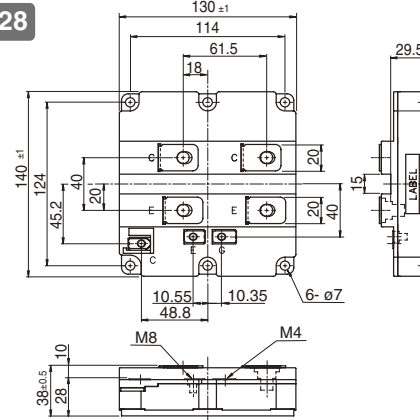

29

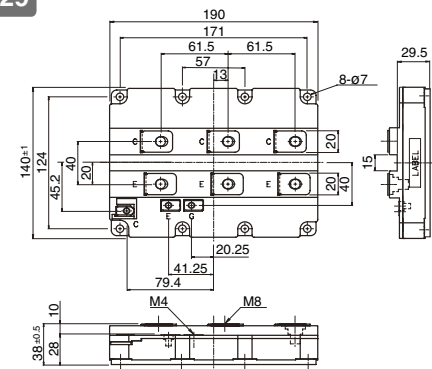

30

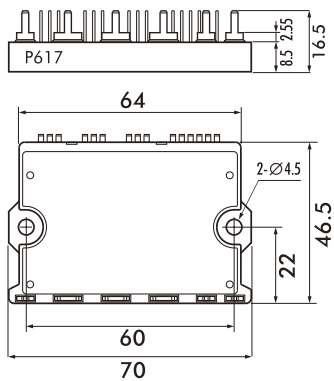

31

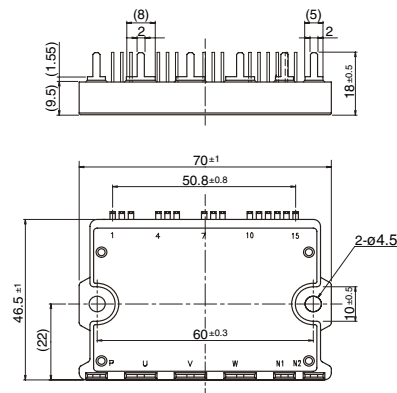

32

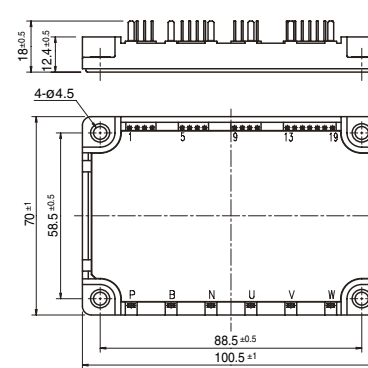

33

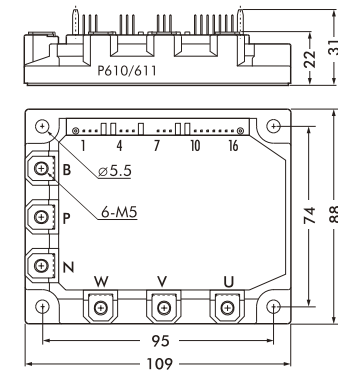



# Package Outlines

mm

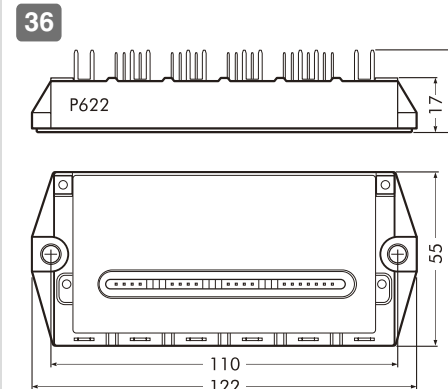
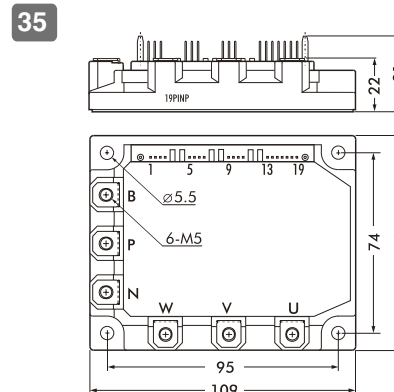
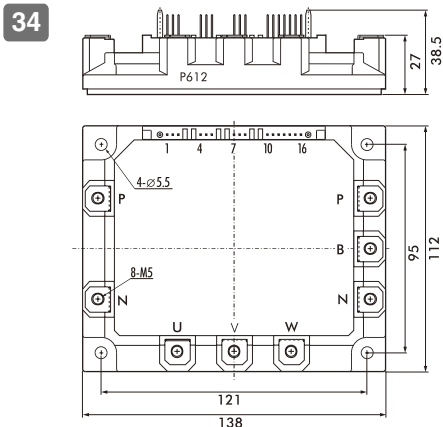

**37** T-pack (S)

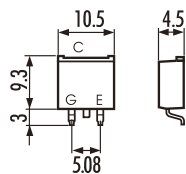

**38** TO-220AB

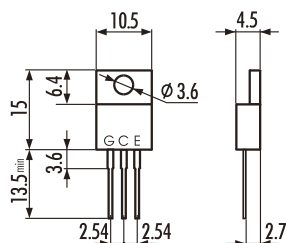

**39** TO-3P

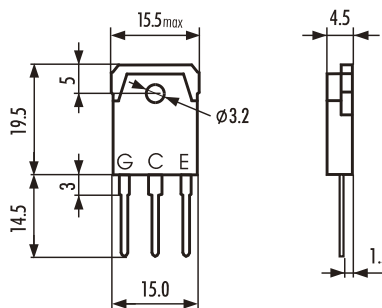

**40** TO-247

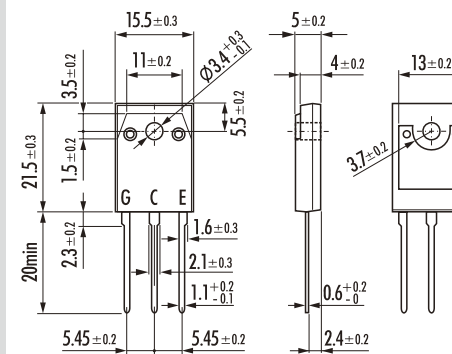

**41** TO-3PL

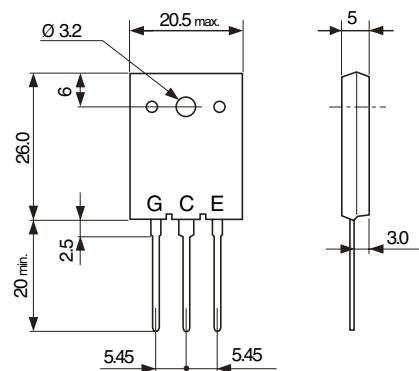

**Fuji Electric Device Technology Co., Ltd.**  
**Semiconductors Group**

<http://www.fujielectric.com/device/semi>  
Gate City Ohsaki, East Tower, 11-2, Osaki 1-chome,  
Shinagawa-ku, Tokyo 141-0032, JAPAN  
Tel: +81-3-5435-7152

**Fuji Electric Device Technology Hong Kong Co., Limited**

Unit 227-230, 2nd Floor, No.1 Science Park West Avenue,  
Hong Kong Science Park, Shatin, N.T., Hong Kong.  
Tel: +852-2664-8699

**Fuji Electric Taiwan Co., Ltd.**

9F-1, No. 111, Sung Chiang Road, Taipei, TAIWAN  
Tel: +886-2-2515-1850

**Fuji Electric Singapore Private Ltd.**

133 New Bridge Road #17-01/02 Chinatown Point, SINGAPORE 059413  
Tel: +65-6535-8998

**Fuji Electric Device Technology America, Inc**

240 Circle Drive North Piscataway, NJ 08854  
Tel: +1-972-733-1700

**Fuji Electric Device Technology Europe GmbH**

Goethering 58, 63067 Offenbach, am Main, F.R. GERMANY  
Tel: +49-69-6690290